

# Hexagon Nuts

## EN ISO 4032 (DIN 934) High Tensile

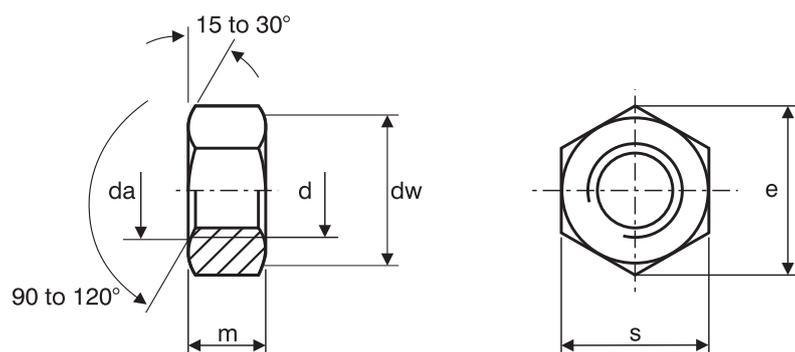

### EN ISO 4032 (DIN934) Dimensions of nuts

Nominal size and thread diameter $d$	$p$	$da$		$dw$	$e$		$m$		$s$	
	(coarse pitch series)	min.	max.	min.	min.	min.	max.	min.	nom.	
M10	1.50	10.00	10.80	14.60	17.77	8.04	8.40	15.73	16.00	
M12	1.75	12.00	13.00	16.60	20.03	10.37	10.80	17.73	18.00	
M14	2.00	14.00	15.10	19.60	23.36	12.10	12.80	20.67	21.00	
M16	2.00	16.00	17.30	22.50	26.75	14.10	14.80	23.67	24.00	
M18	2.50	18.00	19.50	24.90	29.56	15.10	15.80	26.16	27.00	
M20	2.50	20.00	21.60	27.70	32.95	16.90	18.00	29.16	30.00	
M22	2.50	22.00	23.70	31.40	37.29	18.10	19.40	33.00	34.00	
M24	3.00	24.00	25.90	33.30	39.55	20.20	21.50	35.00	36.00	
M27	3.00	27.00	29.10	38.00	45.20	22.50	23.80	40.00	41.00	
M30	3.50	30.00	32.40	42.80	50.85	24.30	25.60	45.00	46.00	
M33	3.50	33.00	35.60	46.60	55.37	27.40	28.70	49.00	50.00	
M36	4.00	36.00	38.90	51.10	60.79	29.40	31.00	53.80	55.00	
M39	4.00	39.00	42.10	55.90	66.44	31.80	33.40	58.80	60.00	
M42	4.50	42.00	45.40	60.00	71.30	32.40	34.00	63.10	65.00	
M45	4.50	45.00	48.60	64.70	76.95	34.40	36.00	68.10	70.00	
M48	5.00	48.00	51.80	69.50	82.60	36.40	38.00	73.10	75.00	
M52	5.00	52.00	56.20	74.20	88.25	40.40	42.00	78.10	80.00	
M56	5.50	56.00	60.50	78.70	93.56	43.40	45.00	82.80	85.00	
M60	5.50	60.00	64.80	83.40	99.21	46.40	48.00	87.80	90.00	
M64	6.00	64.00	69.10	88.20	104.86	49.10	51.00	92.80	95.00	

# Hexagon Nuts

## EN ISO 4032 (DIN 934) High Tensile

### Specification for nuts and reference standards

Characteristic		Standard
Material		Steel
General Requirements	International Standards	ISO 8992
Thread	Tolerance	6H
	International Standard	ISO 724, ISO 965-1
Mechanical Properties	Property Class <sup>a</sup>	d < M3: as agreed M3 ≤ d ≤ M39: 8.8, 10.9 d > M39: as agreed
	International Standards	M3 ≤ d ≤ M39: ISO 898-2 d < M3 and d > M39: as agreed
Tolerances	International Standard	ISO 4759-1
Finish and/or coating		As processed
		Requirements for electroplating are covered in ISO 4042
		Requirements for non-electrolytically applied zinc flake coatings are covered in ISO 10683
		If different electroplating requirements are desired or if requirements are needed for other finishes, they should be agreed between customer and supplier.
		Limits for surface discontinuities are covered in ISO 6157-2
Acceptability		For acceptance procedure, see ISO 3269.
a For other property classes see ISO 898-2.		