

R-XPT-HD Hot Dip Galvanized Throughbolt

Hot Dip Galvanized throughbolt for non-cracked concrete



Product information

Features and benefits

- Increased corrosion resistance due to hot dip zinc external protection layer
- R-XPT is suitable for reduced embedment to avoid contact with reinforcement
- Embedment depth markings help to ensure precise installation of the anchor
- Design of R-XPTII allows drilling and installing directly through the fixture and helps to reduce installation time
- High quality with cost effectiveness
- Cold formed body ensures consistent dimensional accuracy

Applications

- Cladding restraint
- Curtain wall
- Balustrading
- Barriers
- Handrails
- Racking
- Structural steel
- Bollards

Base materials

Approved for use in:

- Non-cracked concrete C20/25-C50/60
- Unreinforced concrete
- Reinforced concrete

Also suitable for use in:

- Natural Stone (after site testing)

Installation guide

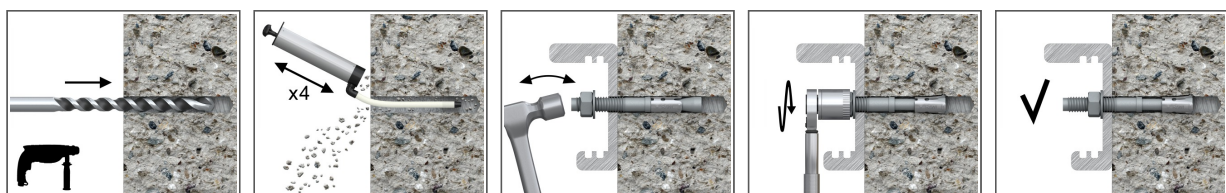

1. Drill a hole of required diameter and depth
2. Clear the hole of drilling dust and debris (using blowpump or equivalent method)
3. Lightly tap the throughbolt through the fixture into hole with a hammer, until fixing depth is reached
4. Tighten to the recommended torque

Product information

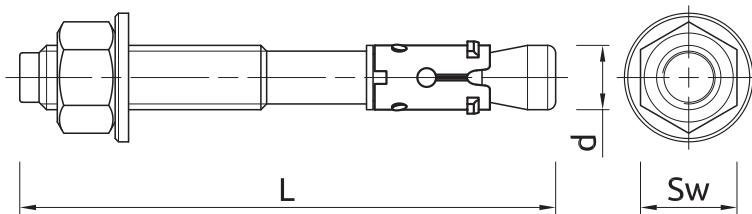

Size	Product Code	Anchor		Fixture		
		Diameter	Length	Max. thickness t_{fix} for:		Hole diameter
		d	L	$h_{nom,red}$	$h_{nom,std}$	d_f
		[mm]	[mm]	[mm]	[mm]	[mm]
M8	R-XPT-HD-08050/5	8	50	5	-	9
	R-XPT-HD-08060/10	8	60	10	-	9
	R-XPT-HD-08065/15	8	65	15	-	9
	R-XPT-HD-08075/10	8	75	25	10	9
	R-XPT-HD-08080/15	8	80	30	15	9
	R-XPT-HD-08095/30	8	95	45	30	9
	R-XPT-HD-08115/50	8	115	65	50	9
R-XPT-HD-08140/75	8	140	90	75	9	
M10	R-XPT-HD-10065/5	10	65	5	-	11
	R-XPT-HD-10080/10	10	80	20	10	11
	R-XPT-HD-10095/25	10	95	35	25	11
	R-XPT-HD-10115/45	10	115	55	45	11
	R-XPT-HD-10130/60	10	130	70	60	11
	R-XPT-HD-10140/70	10	140	80	70	11
M12	R-XPT-HD-12080/5	12	80	5	-	13
	R-XPT-HD-12100/5	12	100	25	5	13
	R-XPT-HD-12120/25	12	120	45	25	13
	R-XPT-HD-12125/30	12	125	50	30	13
	R-XPT-HD-12135/40	12	135	60	40	13
	R-XPT-HD-12150/55	12	150	75	55	13
	R-XPT-HD-12180/85	12	180	105	85	13
	R-XPT-HD-12220/125	12	220	145	125	13
M16	R-XPT-HD-16100/5	16	100	5	-	18
	R-XPT-HD-16105/10	16	105	10	-	18
	R-XPT-HD-16125/5	16	125	25	5	18
	R-XPT-HD-16140/20	16	140	40	20	18
	R-XPT-HD-16150/30	16	150	50	30	18
	R-XPT-HD-16180/60	16	180	80	60	18
	R-XPT-HD-16220/100	16	220	120	100	18
M20	R-XPT-HD-20125/5	20	125	5	-	22
	R-XPT-HD-20160/20	20	160	40	20	22
	R-XPT-HD-20200/60	20	200	80	60	22
M24	R-XPT-HD-24260/100	24	260	115	100	26

Installation data

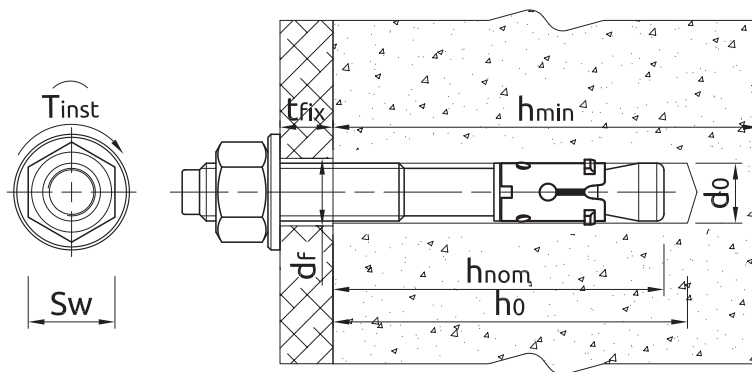

Size			M8	M10	M12	M16	M20	M24
Thread diameter	d	[mm]	8	10	12	16	20	24
Hole diameter in substrate	d _o	[mm]	8	10	12	16	20	24
Installation torque	T _{inst}	[Nm]	15	30	50	100	200	300
Wrench size	Sw	[mm]	13	17	19	24	30	36
STANDARD EMBEDMENT DEPTH								
Min. hole depth in substrate	h _{o,s}	[mm]	60	65	85	105	125	140
Min. installation depth	h _{nom,s}	[mm]	55	59	80	100	119	135
Min. substrate thickness	h _{min,s}	[mm]	100	100	136	170	198	224
Min. spacing	s _{min,s}	[mm]	50	55	75	90	140	180
Min. edge distance	c _{min,s}	[mm]	40	50	65	80	100	200
REDUCED EMBEDMENT DEPTH								
Min. hole depth in substrate	h _{o,r}	[mm]	45	55	65	85	105	125
Min. installation depth	h _{nom,r}	[mm]	40	49	60	80	99	120
Min. substrate thickness	h _{min,r}	[mm]	100	100	100	130	158	194
Min. spacing	s _{min,r}	[mm]	45	55	100	100	125	160
Min. edge distance	c _{min,r}	[mm]	40	65	100	100	125	160

Mechanical properties

Size			M8	M10	M12	M16	M20	M24
Nominal ultimate tensile strength - tension	f _{uk}	[N/mm ²]	620	620	620	620	620	620
Nominal ultimate tensile strength - shear	f _{uk}	[N/mm ²]	520	520	520	520	520	520
Nominal yield strength - tension	f _{yk}	[N/mm ²]	531	531	531	531	531	531
Nominal yield strength - shear	f _{yk}	[N/mm ²]	416	416	416	416	416	416
Cross sectional area - tension	A _s	[mm ²]	25.5	40.7	60.1	106.6	162.9	311
Cross sectional area - shear	A _s	[mm ²]	36.6	58	84.3	157	245	353
Elastic section modulus	W _{el}	[mm ³]	31.2	62.3	109.2	277.5	540.9	935.5
Characteristic bending resistance	M ⁰ _{Rk,s}	[Nm]	17	35	61	155	302	651
Design bending resistance	M	[Nm]	14	28	49	124	241	521

Basic performance data

Performance data for single anchor without influence of edge distance and spacing

Size		M8	M10	M12	M16	M20	M24
MEAN ULTIMATE LOAD							
TENSION LOAD N_{Ru,m}							
Standard embedment depth	[kN]	16.15	20.03	29.95	47.87	58.40	71.73
Reduced embedment depth	[kN]	9.61	12.91	20.95	34.75	46.60	61.57
SHEAR LOAD V_{Ru,m}							
Standard embedment depth	[kN]	12.15	19.24	27.95	51.54	80.85	152.33
Reduced embedment depth	[kN]	12.15	16.00	27.95	51.54	80.85	152.33

Basic performance data

Size		M8	M10	M12	M16	M20	M24
CHARACTERISTIC LOAD							
TENSION LOAD N_{Rk}							
Standard embedment depth	[kN]	9.72	12.61	20.17	27.59	35.02	41.89
Reduced embedment depth	[kN]	6.05	8.87	12.87	19.36	28.05	35.56
SHEAR LOAD V_{Rk}							
Standard embedment depth	[kN]	9.72	12.61	23.30	43.00	67.40	83.78
Reduced embedment depth	[kN]	6.05	8.87	12.87	38.72	56.10	70.72
DESIGN LOAD							
TENSION LOAD N_{Rd}							
Standard embedment depth	[kN]	3.86	5.00	8.00	10.95	13.90	16.62
Reduced embedment depth	[kN]	2.40	3.52	5.11	7.68	11.13	14.03
SHEAR LOAD V_{Rd}							
Standard embedment depth	[kN]	3.86	5.00	16.01	21.90	27.79	33.25
Reduced embedment depth	[kN]	2.40	3.52	5.11	15.37	22.26	28.06

Design performance data

Standard embedment depth

Size			M8	M10	M12	M16	M20	M24
Effective embedment depth	h_{ef}	[mm]	47.00	49.00	68.00	85.00	99.00	112.00
TENSION LOAD								
STEEL FAILURE								
Characteristic resistance	$N_{Rk,s}$	[kN]	15.80	25.20	37.30	66.10	101.00	180.39
Design resistance $\gamma_{Ms} = 1.4$	$N_{Rd,s}$	[kN]	11.29	18.00	26.64	47.21	72.14	128.85
PULL-OUT FAILURE; NON-CRACKED CONCRETE C20/25								
Characteristic resistance	$N_{Rk,p}$	[kN]	9.72	12.61	20.17	27.59	35.02	41.89
Design resistance $\gamma_{Mp} = 2.52$	$N_{Rd,p}$	[kN]	3.86	5.00	8.00	10.95	13.90	16.62
Increasing factors for $N_{Rd,p}$ - C30/37	ψ_c	-	1.00	1.00	1.00	1.00	1.00	1.00
Increasing factors for $N_{Rd,p}$ - C40/50	ψ_c	-	1.00	1.00	1.00	1.00	1.00	1.00
Increasing factors for $N_{Rd,p}$ - C50/60	ψ_c	-	1.00	1.00	1.00	1.00	1.00	1.00
Spacing	$s_{cr,N}$	[mm]	141.00	147.00	204.00	255.00	297.00	336.00
Edge distance	$c_{cr,N}$	[mm]	71.00	74.00	102.00	128.00	149.00	168.00
SHEAR LOAD								
CONCRETE EDGE FAILURE; NON-CRACKED CONCRETE C20/25								
Edge distance	c_1	[mm]	40.00	50.00	65.00	80.00	100.00	200.00
Characteristic resistance for c_1	$V_{Rk,c}$	[kN]	5.03	7.07	10.96	15.77	22.56	58.63
Design resistance $\gamma_{Mc} = 1.8$	$V_{Rd,c}$	[kN]	2.79	3.93	6.09	8.76	12.53	32.57
CONCRETE PRY-OUT FAILURE; NON-CRACKED CONCRETE C20/25								
Factor	k	-	1.00	1.00	2.00	2.00	2.00	2.00
Characteristic resistance	$V_{Rk,cp}$	[kN]	9.72	12.61	40.34	55.18	70.04	83.78
Design resistance $\gamma_{Mc} = 2.52$	$V_{Rd,cp}$	[kN]	3.86	5.00	16.01	21.90	27.79	33.25
STEEL FAILURE								
Characteristic resistance without lever arm	$V_{Rk,s}$	[kN]	10.10	16.00	23.30	43.00	67.40	126.94
Design resistance $\gamma_{Ms} = 1.25$	$V_{Rd,s}$	[kN]	8.08	12.80	18.64	34.40	53.92	101.55

Design performance data

Reduced embedment depth

Size			M8	M10	M12	M16	M20	M24
Effective embedment depth	h_{ef}	[mm]	32.00	39.00	48.00	65.00	79.00	97.00
TENSION LOAD								
STEEL FAILURE								
Characteristic resistance	$N_{Rk,s}$	[kN]	15.80	25.20	37.30	66.10	101.00	180.39
Design resistance $V_{Ms} = 1.4$	$N_{Rd,s}$	[kN]	11.29	18.00	26.64	47.21	72.14	128.85
PULL-OUT FAILURE; NON-CRACKED CONCRETE C20/25								
Characteristic resistance	$N_{Rk,p}$	[kN]	6.05	8.87	12.87	19.36	28.05	35.36
Design resistance $V_{Mp} = 2.52$	$N_{Rd,p}$	[kN]	2.40	3.52	5.11	7.68	11.13	14.03
Increasing factors for $N_{Rd,p}$ - C30/37	ψ_c	-	1.00	1.00	1.00	1.00	1.00	1.00
Increasing factors for $N_{Rd,p}$ - C40/50	ψ_c	-	1.00	1.00	1.00	1.00	1.00	1.00
Increasing factors for $N_{Rd,p}$ - C50/60	ψ_c	-	1.00	1.00	1.00	1.00	1.00	1.00
Spacing	$s_{cr,N}$	[mm]	96.00	117.00	144.00	195.00	237.00	291.00
Edge distance	$c_{cr,N}$	[mm]	48.00	59.00	72.00	98.00	119.00	146.00
EDGE FAILURE; NON-CRACKED CONCRETE C20/25								
Edge distance	c_1	[mm]	40.00	65.00	100.00	100.00	125.00	160.00
Characteristic resistance for c_1	$V_{Rk,c}$	[kN]	4.70	9.67	18.36	20.04	28.81	42.54
Design resistance $V_{Mc} = 1.8$	$V_{Rd,c}$	[kN]	2.61	5.37	10.20	11.13	16.00	23.63
CONCRETE PRY-OUT FAILURE; NON-CRACKED CONCRETE C20/25								
Factor	k	-	1.00	1.00	1.00	2.00	2.00	2.00
Characteristic resistance	$V_{Rk,cp}$	[kN]	6.05	8.87	12.87	38.72	56.10	42.54
Design resistance $V_{Mc} = 2.52$	$V_{Rd,cp}$	[kN]	2.40	3.52	5.11	15.37	22.26	28.06
STEEL FAILURE								
Characteristic resistance without lever arm	$V_{Rk,s}$	[kN]	10.10	16.00	23.30	43.00	67.40	126.94
Design resistance $V_{Ms} = 1.25$	$V_{Rd,s}$	[kN]	8.08	12.80	18.64	34.40	53.92	101.55

Product commercial data

Product Code	Anchor		Quantity [pcs]			Weight [kg]			Bar Codes
	Diameter [mm]	Length [mm]	Box	Outer	Pallet	Box	Outer	Pallet	
R-XPT-HD-08050/5	8	50	100	100	16000	2.3	2.3	404.4	5906675277875
R-XPT-HD-08060/10	8	60	100	100	16000	2.8	2.8	470.0	5906675234007
R-XPT-HD-08065/15	8	65	100	100	16000	2.9	2.9	490.8	5906675277882
R-XPT-HD-08075/10	8	75	100	100	16000	3.2	3.2	542.0	5906675234014
R-XPT-HD-08080/15	8	80	100	100	16000	3.3	3.3	553.2	5906675277899
R-XPT-HD-08095/30	8	95	100	100	12000	3.8	3.8	482.4	5906675234618
R-XPT-HD-08115/50	8	115	100	100	12000	4.4	4.4	561.6	5906675234038
R-XPT-HD-08140/75	8	140	100	100	16000	5.2	5.2	865.2	5906675234045
R-XPT-HD-10065/5	10	65	50	50	8000	2.4	2.4	414.0	5906675234052
R-XPT-HD-10080/10	10	80	50	50	8000	2.8	2.8	473.2	5906675234069
R-XPT-HD-10095/25	10	95	50	50	8000	3.2	3.2	534.8	5906675234076
R-XPT-HD-10115/45	10	115	50	50	6000	3.7	3.7	472.2	5906675234083
R-XPT-HD-10130/60	10	130	50	50	8000	4.0	4.0	676.4	5906675277905
R-XPT-HD-10140/70	10	140	50	50	8000	4.4	4.4	728.4	5906675234090
R-XPT-HD-12080/5	12	80	50	50	8000	4.1	4.1	684.4	5906675234106
R-XPT-HD-12100/5	12	100	50	50	8000	4.8	4.8	799.6	5906675234113
R-XPT-HD-12120/25	12	120	50	50	6000	5.6	5.6	698.4	5906675277912
R-XPT-HD-12125/30	12	125	50	50	6000	5.7	5.7	717.0	5906675234625
R-XPT-HD-12135/40	12	135	50	50	6000	6.3	6.3	781.8	5906675277929
R-XPT-HD-12150/55	12	150	50	50	4000	6.7	6.7	564.0	5906675234137
R-XPT-HD-12180/85	12	180	50	50	4000	7.8	7.8	656.0	5906675234144
R-XPT-HD-12220/125	12	220	50	50	4000	9.3	9.3	775.6	5906675234151

Product commercial data

Product Code	Anchor		Quantity [pcs]			Weight [kg]			Bar Codes
	Diameter [mm]	Length [mm]	Box	Outer	Pallet	Box	Outer	Pallet	
R-XPT-HD-16100/5	16	100	25	25	4000	4.4	4.4	733.2	5906675234168
R-XPT-HD-16105/10	16	105	25	25	4000	4.0	4.0	661.2	5906675277936
R-XPT-HD-16125/5	16	125	25	25	4000	5.4	5.4	890.0	5906675234175
R-XPT-HD-16140/20	16	140	25	25	4000	5.9	5.9	975.2	5906675277943
R-XPT-HD-16150/30	16	150	25	25	4000	6.1	6.1	1003.6	5906675249728
R-XPT-HD-16180/60	16	180	25	25	3000	7.2	7.2	898.8	5906675249735
R-XPT-HD-16220/100	16	220	25	25	3000	8.4	8.4	1040.1	5906675234205
R-XPT-HD-20125/5	20	125	25	25	3000	8.5	8.5	1051.2	5906675234212
R-XPT-HD-20160/20	20	160	25	25	2000	10.3	10.3	855.6	5906675234229
R-XPT-HD-20200/60	20	200	10	10	1200	5.0	5.0	624.1	5906675234236
R-XPT-HD-24260/100	24	260	10	10	1200	9.4	9.4	1155.5	5906675249742