



**Technical and Test Institute  
for Construction Prague**

Prosecká 811/76a  
190 00 Prague  
Czech Republic  
eota@tzus.cz



Member of



www.eota.eu

## European Technical Assessment

## ETA 17/0782 of 21/09/2017

**Technical Assessment Body issuing the ETA:** Technical and Test Institute  
for Construction Prague

**Trade name of the construction product**

Rawl R-XPTII-A4 Anchor

**Product family to which the construction  
product belongs**

Product area code: 33  
Torque controlled expansion anchor  
for use in uncracked concrete

**Manufacturer**

Rawlplug S.A.  
Ul. Kwidzyńska 6  
51-416 Wrocław  
Poland

**Manufacturing plant**

Manufacturing Plant No 2

**This European Technical Assessment  
contains**

10 pages including 8 Annexes which form  
an integral part of this assessment

**This European Technical Assessment is  
issued in accordance with regulation  
(EU) No 305/2011, on the basis of**

EAD 330232-00-0601  
Mechanical fasteners for use in concrete

**This version is a corrigendum to**

ETA 17/0782 of 21/09/2017

Translations of this European Technical Assessment in other languages shall fully correspond to the original issued document and should be identified as such.

Communication of this European Technical Assessment, including transmission by electronic means, shall be in full (excepted the confidential Annex(es) referred to above). However, partial reproduction may be made, with the written consent of the issuing Technical Assessment Body - Technical and Test Institute for Construction Prague. Any partial reproduction has to be identified as such

## 1. Technical description of the product

The Rawl R-XPTII-A4 Anchor are through-fixing torque-controlled expansion anchors in sizes of M8, M10, M12 and M16. Each type comprises a special bolt with a taper, an expansion sleeve, a hexagonal nut and a washer. The anchors are made from A4 grade stainless steel.

The anchor is installed in a drilled hole; tightening the nut draws the cone into the sleeve. The expansion of this sleeve applies the anchorage.

The installed anchor is shown in Annex 1.

## 2. Specification of the intended use in accordance with the applicable EAD

The performances given in Section 3 are only valid if the anchor is used in compliance with the specifications and conditions given in Annex B.

The provisions made in this European Technical Assessment are based on an assumed working life of the anchor of 50 years. The indications given on the working life cannot be interpreted as a guarantee given by the producer, but are to be regarded only as a means for choosing the products in relation to the expected economically reasonable working life of the works.

## 3. Performance of the product and references to the methods used for its assessment

### 3.1 Mechanical resistance and stability (BWR 1)

Essential characteristic	Performance
Characteristic resistance (static and quasi-static loading)	See Annex C 1 and C 2
Displacement	See Annex C 1 and C 2

### 3.2 Safety in case of fire (BWR 2)

Essential characteristic	Performance
Reaction to fire	Class A1 according to EN 13501-1
Resistance to fire	No performance assessed

## 4. Assessment and verification of constancy of performance (AVCP) system applied with reference to its legal base

According to the Decision 97/463/EC of the European Commission<sup>1</sup>, the system 1 of assessment verification of constancy of performance (see Annex V to the Regulation (EU) No 305/2011) apply.

## 5. Technical details necessary for the implementation of the AVCP system, as provided in the applicable EAD

Technical details necessary for the implementation of the AVCP system are laid down in the control plan deposited at Technical and Test Institute for Construction Prague.

Issued in Prague on 21.09.2017

By

**Ing. Mária Schaan**

Head of the Technical Assessment Body

<sup>1</sup> Official Journal of the European Communities L 198/31 25.7.1997

**Rawl R-XPTII-A4 Anchor - Installed anchor**

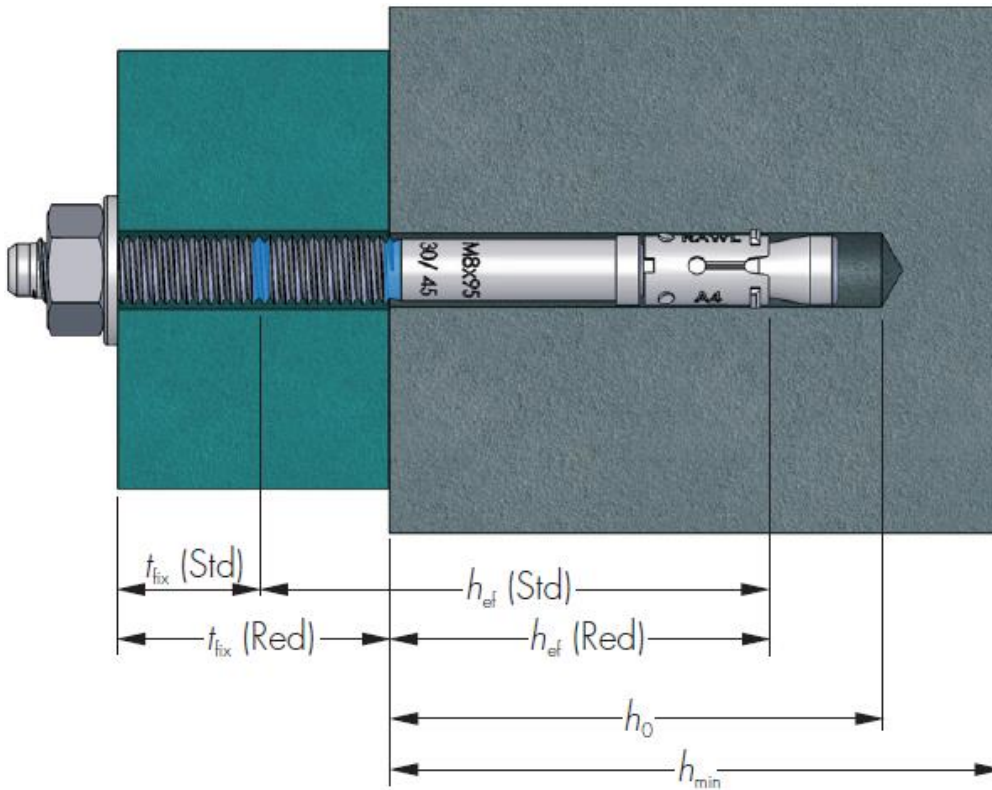

**Rawl R-XPTII-A4 Anchor - components**

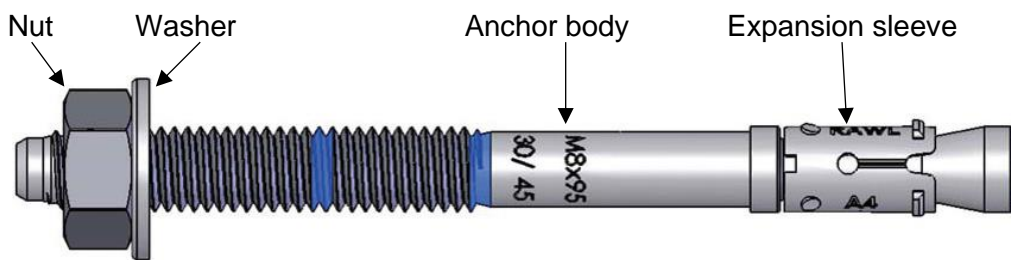

**Rawl R-XPTII-A4 Anchor**

**Product description**  
Installed conditions and components

**Annex A 1**

**Table A1 - Materials**

Component	Material
Anchor body	Steel rod on coil cold forged bolts Steel grade 1.4578, EN 10263-5
Expansion sleeve	Steel grade 1.4401, EN 10088-2
Hexagonal nut	Steel grade A4, class 70 or 80, ISO 3506-2
Washer	according DIN 125A or DIN 9021

**Table A2 – Material properties**

Component	M8 – M10	M12-M16
Anchor body – ultimate tensile strength [N/mm <sup>2</sup> ]	600-700	550-650
	M8-M16	
Expansion sleeve – ultimate tensile strength [N/mm <sup>2</sup> ]	530-680	

**Table A3 – Marking**

<b>M8</b>																		
Bolt length [mm]	60	65	75	80	85	90	95	100	105	115	120	140	150	160				
Head marking	B	b	C	d	D	e	E	F	f	G	H	K	L	M				
Bolt marking	-/10	-/15	10/25	15/30	20/35	25/40	30/45	35/50	40/55	50/65	55/70	75/90	85/100	95/110				
<b>M10</b>																		
Bolt length [mm]	65	80	85	90	95	115	120	130	140	150	180							
Head marking	B	D	d	e	E	G	H	J	K	L	P							
Bolt marking	-/5	-/20	5/25	10/30	15/35	35/55	40/60	50/70	60/80	70/90	100/120							
<b>M12</b>																		
Bolt length [mm]	80	100	105	110	115	120	125	135	140	150	160	180	200	220	240	250	260	280
Head marking	D	F	f	G	g	h	H	J	K	L	M	P	R	S	T	U	V	X
Bolt marking	-/5	5/25	10/30	15/35	20/40	25/45	30/50	40/60	45/65	55/75	65/85	85/105	105/125	125/145	145/165	155/175	165/185	185/205
<b>M16</b>																		
Bolt length [mm]	100	105	125	130	140	150	160	180	200	220	250	280	300					
Head marking	F	f	H	J	K	L	M	P	R	S	U	X	Y					
Bolt marking	-/5	-/10	5/25	10/30	20/40	30/50	40/60	60/80	80/100	100/120	130/150	160/180	180/200					

**Rawl R-XPTII-A4 Anchor**
**Product description**  
 Materials  
 Marking
**Annex A 2**

## Specifications of intended use

### Anchorage subject to:

- Static and quasi-static load.

### Base materials

- Uncracked concrete.
- Reinforced or unreinforced normal weight concrete of strength class C20/25 at minimum and C50/60 at maximum according EN 206-1:2000-12.

### Use conditions (Environmental conditions)

- Structures subject to dry internal conditions.
- Structures subject to external atmospheric exposure (including industrial and marine environment) or exposure to permanently damp internal condition, if no particular aggressive conditions exist.

Note: Particular aggressive conditions are e.g. permanent, alternating immersion in seawater or the splash zone of seawater, chloride atmosphere of indoor swimming pools or atmosphere with extreme chemical pollution (e.g. in desulphurization plants or road tunnels where de-icing materials are used).

### Design:

- The anchorages are designed in accordance with the FprEN 1992-4:2016 and EOTA Technical Report TR 055, December 2016 under the responsibility of an engineer experienced in anchorages and concrete work.
- Verifiable calculation notes and drawings are prepared taking account of the loads to be anchored. The position of the anchor is indicated on the design drawings.

### Installation:

- Anchor installation carried out by appropriately qualified personnel and under the supervision of the person responsible for technical matters of the site.
- Use of the anchor only as supplied by the manufacturer without exchanging any components of the anchor.
- Anchor installation in accordance with the manufacturer's specifications and drawings using the appropriate tools.
- Effective anchoring depth, edge distance and spacing not less than the specified values without minus tolerance.
- In case of aborted drill hole: new drilling at a minimum distance away of twice the depth of the aborted hole or smaller distance if the aborted drill hole is filled with high strength mortar and if under shear or oblique tension load it is not in the direction of load application.

**Rawl R-XPTII-A4 Anchor**

**Intended use**  
Specifications

**Annex B 1**

**Table B1 - Installation parameters**

Size	Drill hole diameter	Bolt length	Thread length	Hole diameter in fixture	Standard embedment				Reduced embedment				Installation torque
					Min. hole depth	Nominal embedment depth	Effective embedment depth	Max. fixture thickness	Min. hole depth	Nominal embedment depth	Effective embedment depth	Max. fixture thickness	
	d <sub>0</sub> [mm]	l [mm]	l <sub>G</sub> [mm]	d <sub>f</sub> [mm]	h <sub>0</sub> [mm]	h <sub>nom</sub> [mm]	h <sub>ef</sub> [mm]	t <sub>fix</sub> [mm]	h <sub>0</sub> [mm]	h <sub>nom</sub> [mm]	h <sub>ef</sub> [mm]	t <sub>fix</sub> [mm]	T <sub>inst</sub> [N.m]
M8	8	60	25	9	-	-	-	-	50	40	32	10	15
		65	30	9	-	-	-	-	50	40	32	15	
		75	35	9	65	55	47	10	50	40	32	25	
		80	40	9	65	55	47	15	50	40	32	30	
		85	45	9	65	55	47	20	50	40	32	35	
		90	50	9	65	55	47	25	50	40	32	40	
		95	55	9	65	55	47	30	50	40	32	45	
		100	60	9	65	55	47	35	50	40	32	50	
		105	65	9	65	55	47	40	50	40	32	55	
		115	75	9	65	55	47	50	50	40	32	65	
		120	80	9	65	55	47	55	50	40	32	70	
140	100	9	65	55	47	75	50	40	32	90			
150	100	9	65	55	47	85	50	40	32	100			
160	100	9	65	55	47	95	50	40	32	110			
M10	10	65	21	11	-	-	-	-	59	49	39	5	30
		80	31	11	-	-	-	-	59	49	39	20	
		85	36	11	79	69	59	5	59	49	39	25	
		90	41	11	79	69	59	10	59	49	39	30	
		95	46	11	79	69	59	15	59	49	39	35	
		115	66	11	79	69	59	35	59	49	39	55	
		120	71	11	79	69	59	40	59	49	39	60	
		130	81	11	79	69	59	50	59	49	39	70	
		140	91	11	79	69	59	60	59	49	39	80	
150	101	11	79	69	59	70	59	49	39	90			
180	100	11	79	69	59	100	59	49	39	120			
M12	12	80	30	13	-	-	-	-	70	60	48	5	50
		100	40	13	90	80	68	5	70	60	48	25	
		105	45	13	90	80	68	10	70	60	48	30	
		110	50	13	90	80	68	15	70	60	48	35	
		115	55	13	90	80	68	20	70	60	48	40	
		120	60	13	90	80	68	25	70	60	48	45	
		125	65	13	90	80	68	30	70	60	48	50	
		135	75	13	90	80	68	40	70	60	48	60	
		140	80	13	90	80	68	45	70	60	48	65	
		150	90	13	90	80	68	55	70	60	48	75	
		160	100	13	90	80	68	65	70	60	48	85	
		180	100	13	90	80	68	85	70	60	48	105	
		200	100	13	90	80	68	105	70	60	48	125	
		220	100	13	90	80	68	125	70	60	48	145	
240	100	13	90	80	68	145	70	60	48	165			
250	100	13	90	80	68	155	70	60	48	175			
260	100	13	90	80	68	165	70	60	48	185			
280	100	13	90	80	68	185	70	60	48	205			
M16	16	100	30	18	-	-	-	-	90	80	65	5	100
		105	35	18	-	-	-	-	90	80	65	10	
		125	45	18	110	100	85	5	90	80	65	25	
		130	50	18	110	100	85	10	90	80	65	30	
		140	60	18	110	100	85	20	90	80	65	40	
		150	70	18	110	100	85	30	90	80	65	50	
		160	80	18	110	100	85	40	90	80	65	60	
		180	100	18	110	100	85	60	90	80	65	80	
		200	100	18	110	100	85	80	90	80	65	100	
		220	100	18	110	100	85	100	90	80	65	120	
		250	100	18	110	100	85	130	90	80	65	150	
280	100	18	110	100	85	160	90	80	65	180			
300	100	18	110	100	85	180	90	80	65	200			

**Rawl R-XPTII-A4 Anchor**

**Intended use**  
Installation parameters

**Annex B 2**

**Table B2 - Installation parameters – Minimum spacing and edge distance**

Size	M8		M10		M12		M16		
	Red <sup>1)</sup>	Std	Red <sup>1)</sup>	Std	Red	Std	Red	Std	
Minimum thickness of concrete member $h_{min}$	[mm]	100	100	100	120	100	140	130	170
Minimum spacing for edge distance $c \geq$	$s_{min}$	[mm]	65	65	115	90	150	110	190
		[mm]	65	65	110	80	120	85	120
Minimum edge distance for spacing $s \geq$	$c_{min}$	[mm]	50	50	80	60	100	85	120
		[mm]	100	100	150	125	190	110	190

<sup>1)</sup> Use restricted to anchoring statically indeterminate structural components

**Pre-torque installation**

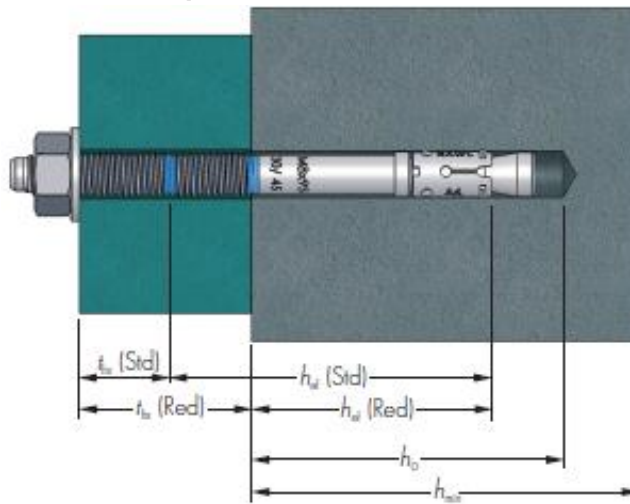

**Post-torque installation**

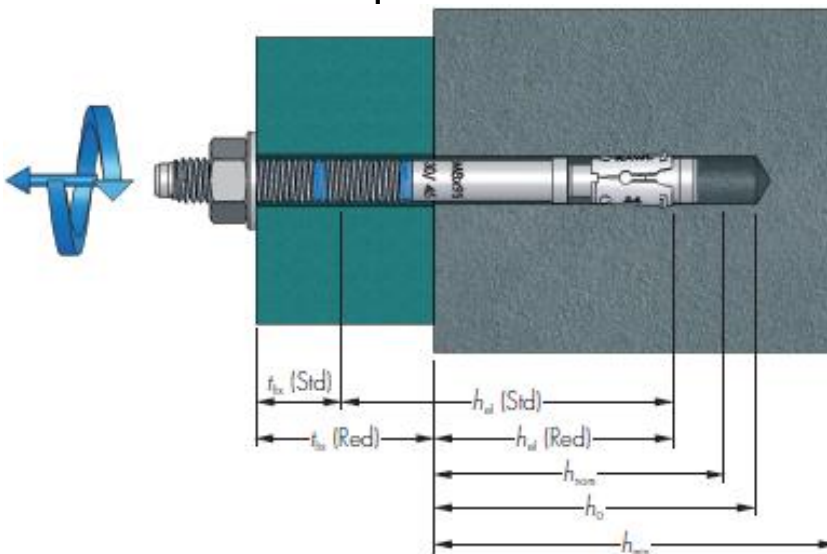

**Rawl R-XPTII-A4 Anchor**

**Intended use**  
Installation parameters

**Annex B 2**

## Installation instructions

1.



Drill a hole of required diameter and depth

2.



Clear the hole of drilling dust and debris (using blowpump or equivalent method)

3.



Lightly tap the throughbolt through the fixture into hole until fixing depth is reached

4.



Tighten to the recommended torque

5.



Assembled condition of anchor

**Rawl R-XPTII-A4 Anchor**

**Intended use**  
Installation instructions

**Annex B 3**



**Table C1 – Characteristic resistance under tension load**

Steel failure			M8		M10		M12		M16	
			Red <sup>1)</sup>	Std	Red <sup>1)</sup>	Std	Red	Std	Red	Std
Size										
Characteristic resistance	$N_{Rk,s}$	[kN]	21,2		33,6		44,8		82,6	
Partial safety factor	$\gamma_{Ms}$	[-]	1,5		1,5		1,5		1,5	

Pull-out failure											
Characteristic resistance in uncracked concrete C20/25	$N_{Rk,p}$	[kN]	7,5	9,0	12,0	16,0	- <sup>2)</sup>	25,0	- <sup>2)</sup>	- <sup>2)</sup>	
Installation safety factor	$\gamma_{inst}$	[-]	1,2	1,2	1,2	1,0	1,0	1,0	1,0	1,0	
Increasing factor											
Uncracked concrete	C30/37	$\psi_c$	[-]	1,17	1,22	1,22	1,22	1,22	1,22	1,22	
	C40/50			1,32	1,41	1,41	1,41	1,41	1,41	1,41	1,41
	C50/60			1,42	1,55	1,55	1,55	1,55	1,55	1,55	1,55

Concrete cone failure										
Factor for concrete cone failure for uncracked concrete	$k_{ucr,N}$	[-]	11,0							
Installation safety factor	$\gamma_{inst}$	[-]	1,2	1,2	1,2	1,0	1,0	1,0	1,0	1,0
Effective anchorage depth	$h_{ef}$	[mm]	32	47	39	59	48	68	65	85
Spacing	$s_{cr,N}$	[mm]	96	141	117	177	144	204	195	255
Edge distance	$c_{cr,N}$	[mm]	48	71	59	89	72	102	98	128

Splitting failure										
Spacing	$s_{cr,sp}$	[mm]	160	240	200	300	250	340	320	430
Edge distance	$c_{cr,sp}$	[mm]	80	120	100	150	125	170	160	215
Installation safety factor	$\gamma_{inst}$	[-]	1,2	1,2	1,2	1,0	1,0	1,0	1,0	1,0

<sup>1)</sup> Use restricted to anchoring statically indeterminate structural components

<sup>2)</sup> Pull-out failure mode is not decisive

**Table C2 – Displacement under tension load**

Size			M8		M10		M12		M16	
			Red <sup>1)</sup>	Std	Red <sup>1)</sup>	Std	Red	Std	Red	Std
Tension load in uncracked concrete	N	[kN]	3,0	3,6	4,8	7,6	8,0	11,9	12,6	18,8
Displacement	$\delta_{N0}$	[mm]	0,1	0,3	0,2	0,2	0,1	0,5	0,3	0,5
	$\delta_{N\infty}$	[mm]	0,7	0,7	0,7	0,7	0,7	0,7	0,7	0,7

<sup>1)</sup> Use restricted to anchoring statically indeterminate structural components

<b>Rawl R-XPTII-A4 Anchor</b>	<b>Annex C 1</b>
<b>Performances</b>	
Characteristic resistance under tension load Displacement under tension load	

**Table C3 – Characteristic resistance under shear load**

Steel failure without lever arm			M8		M10		M12		M16	
			Red <sup>1)</sup>	Std	Red <sup>1)</sup>	Std	Red	Std	Red	Std
Size										
Characteristic resistance	$V^0_{Rk,s}$	[kN]	11,7		18,5		24,6		45,4	
Ductility factor	$k_7$	[-]	0,8		0,8		0,8		0,8	
Partial safety factor	$\gamma_{Ms}$	[-]	1,25		1,25		1,25		1,25	

Steel failure with lever arm			M8		M10		M12		M16	
Characteristic resistance	$M^0_{Rk,s}$	[Nm]	22		45		72		180	
Partial safety factor	$\gamma_{Ms}$	[-]	1,25		1,25		1,25		1,25	

Concrete pry-out failure			M8		M10		M12		M16	
Factor	$k_8$	[-]	1,0	1,0	1,2	1,0	2,0	1,0	2,0	2,0
Installation safety factor	$\gamma_{inst}$	[-]	1,2	1,2	1,2	1,2	1,2	1,2	1,2	1,2

Concrete edge failure			M8		M10		M12		M16	
Effective length of anchor	$l_f$	[mm]	32	47	39	59	48	68	65	85
Anchor diameter	$d_{nom}$	[mm]	8		10		12		16	
Installation safety factor	$\gamma_{inst}$	[-]	1,2	1,2	1,2	1,0	1,0	1,0	1,0	1,0

<sup>1)</sup> Use restricted to anchoring statically indeterminate structural components

**Table C4 – Displacement under shear load**

Size			M8		M10		M12		M16	
			Red <sup>1)</sup>	Std	Red <sup>1)</sup>	Std	Red	Std	Red	Std
Shear load in uncracked concrete	$V$	[kN]	6,7	6,7	5,8	10,6	14,1	14,1	25,9	25,9
Displacement	$\delta_{v0}$	[mm]	3,0	3,0	1,5	2,7	2,5	2,5	2,2	2,2
	$\delta_{v\infty}$	[mm]	4,5	4,5	2,2	4,1	3,8	3,8	3,3	3,3

<sup>1)</sup> Use restricted to anchoring statically indeterminate structural components

**Rawl R-XPTII-A4 Anchor**

**Performances**

Characteristic resistance under shear load  
Displacement under shear load

**Annex C 2**