



Designated according to The Construction Products (Amendment etc.) (EU Exit) Regulations 2020

UK Technical Assessment	UKTA-0836-22/6261 of 25/11/2022
Technical Assessment Body issuing the UK Technical Assessment:	British Board of Agrément
Trade name of the construction product:	VJ Technology Injection System XPE440 for rebar connection
Product family to which the construction product belongs:	Product code 33 - Fixings
Manufacturer:	VJ Technology Ltd. Brunswick Road Cobbs Wood Ind. Estate ASHFORD KENT TN23 1EN UK
Manufacturing plant(s):	VJ Technology Plant 1
This UK Technical Assessment contains:	24 pages including 3 annexes which form an integral part of this assessment
This UK Technical Assessment is issued in accordance with The Construction Products (Amendment etc.) (EU Exit) Regulations 2020 on the basis of:	EAD 330087-00-0601

Communication of this UK Technical Assessment, including transmission by electronic means, shall be in full. However, partial reproduction may be made with the written consent of the British Board of Agrément. Any partial reproduction must be identified as such.

1 Technical description of the product

The subject of this European Technical Assessment is the VJ Technology Injection System XPE440 for rebar connection, a post-installed connection, by anchoring or overlap connection joint, of reinforcing bars (rebars) in existing structures made of normal weight concrete in accordance with the regulations for reinforced concrete construction.

Reinforcing bars manufactured from steel with a diameter ϕ from 8 to 40 mm or the tension anchor ZA from sizes M12 to M24 according to Annex A and injection mortar XPE440 are used for rebar connections. The rebar is placed into a drilled hole filled with injection mortar and is anchored via the bond between rebar, injection mortar and concrete.

The product description is given in Annex A.

2 Specification of the intended use(s) in accordance with the applicable UK Assessment Document (hereinafter UKAD)

The performances given in Section 3 are only valid if the anchor is used in compliance with the specifications and conditions given in Annex B.

The verifications and assessment methods on which this European Technical Assessment is based lead to the assumption of a working life of the rebar connection of at least 50 years. The indications given on the working life cannot be interpreted as a guarantee given by the producer but are to be regarded only as a means for choosing the right products in relation to the expected economically reasonable working life of the works.

3 Performance of the product and references to the methods used for its assessment

3.1 Mechanical resistance and stability (BWR 1)

Essential characteristic	Performance
Characteristic resistance under static and quasi-static loading	See Annex C1

3.2 Safety in case of fire (BWR 2)

Essential characteristic	Performance
Reaction to fire	Rebar connections satisfy requirements for Class A1
Resistance to fire	See Annex C2 and C3

3.3 Health, hygiene, and the environment (BWR 3)

Not relevant

3.4 Safety and accessibility in use (BWR 4)

Not relevant.

3.5 Protection against noise (BWR 5)

Not relevant.

3.6 Energy economy and heat retention (BWR 6)

Not relevant.

3.7 Sustainable use of natural resources (BWR 7)

No performance assessed.

4 Assessment and verification of constancy of performance (hereinafter AVCP) system applied

4.1 System of assessment and verification of constancy of performance

According to UKAD No. 330087-00-0601 and Annex V of the Construction Products Regulation (Regulation (EU) 305/2011 as brought into UK law and amended, the system of assessment and verification of constancy of performance (AVCP) 1 applies.

5 Technical details necessary for the implementation of the AVCP system, as provided for in the applicable UKAD

Technical details necessary for the implementation of the AVCP system are laid down in the control plan deposited with the British Board of Agrément and made available to the UK Approved Bodies involved in the conformity attestation process.

5.1 UKCA marking for the product/system must contain the following information:

- Identification number of the Approved Body
- Name/address of the manufacturer of the product/ system
- Marking with intention of clarification of intended use
- Date of marking
- Number of certificate of constancy of performance
- UKTA number.

On behalf of the British Board of Agrément



Date of Issue: 25 November 2022

Hardy Giesler
Chief Executive Officer



British Board of Agrément,
1st Floor Building 3
Hatters Lane
Croxley Park
Watford
WD18 8YG

ANNEXES

- Annex A1 – Product description – Installed condition and examples of use for rebars
- Annex A2 – Product description – Installed condition and examples of use for tension anchors ZA
- Annex A3 – Product description – Injection mortar/Static mixer/Rebar/Tension Anchor ZA
- Annex A4 – Product description – Materials Rebar
- Annex A5 – Product description – Specifications Tension Anchor ZA
- Annex B1 – Intended use – Specifications
- Annex B2 – Intended use – General construction rules for post-installed rebars
- Annex B3 – Intended use – General construction rules for tension anchors
- Annex B4 – Intended use – Minimum concrete cover – Maximum embedment depth
- Annex B5 – Intended use – Dispensing, cleaning, and installation tools
- Annex B6 – Intended use – Installation tools
- Annex B7 – Intended use – Installation instruction: Bore hole drilling and cleaning (HD, HDB and CD)
- Annex B8 – Intended use – Installation instruction: Bore hole drilling and cleaning (DD)
- Annex B9 – Intended use – Installation instruction: Preparation of bar and cartridge – Filling the bore hole
- Annex B10 – Intended use – Installation instruction: Inserting rebar
- Annex C1 – Performances – Amplification factor α_b , Reduction factor k_b – Design values of ultimate bond resistance $f_{bd,PIR}$
- Annex C2 – Performances – Design value of bond strength $f_{bd,fi}$ under fire exposure
- Annex C3 – Performances – Design value of steel strength $\sigma_{Rd,s,fi}$ for tension anchor ZA under fire exposure

Installation post installed rebar

Figure A1: Overlapping joint for rebar connections of slabs and beams

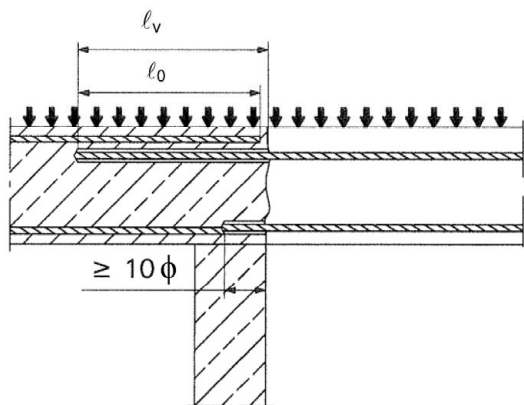

Figure A3: End anchoring of slabs or beams (e.g. designed as simply supported)

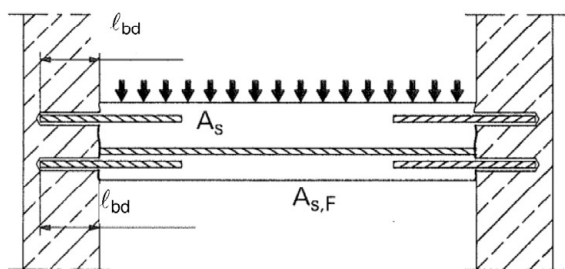

Figure A5: Anchoring of reinforcement to cover the line of acting tensile force

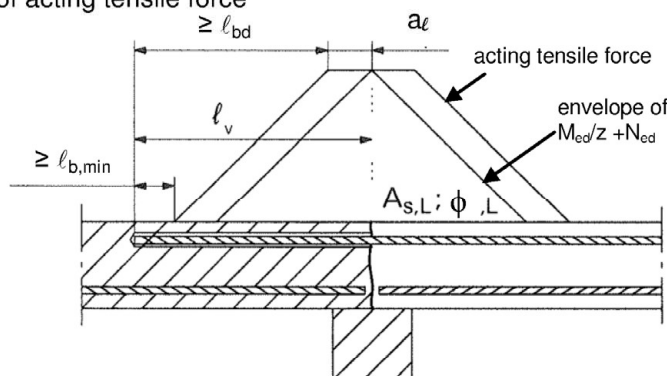

Figure A2: Overlapping joint at a foundation of a wall or column where the rebar are stressed in tension

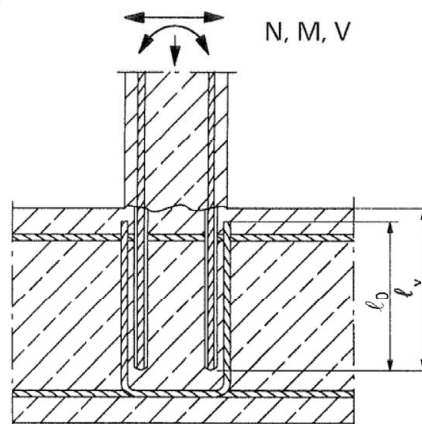
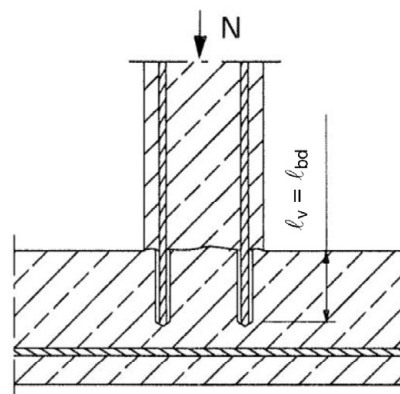

Figure A4: Rebar connection for components stressed primarily in compression. The rebar are stressed in compression



Note to Figure A1 to A5:

In the Figures no transverse reinforcement is plotted, the transverse reinforcement shall comply with BS EN 1992-1-1: 2004 + A1: 2014

Preparing of joints according to Annex B 2

<p>VJ Technology Injection System XPE440 for rebar connection</p>	<p>Annex A 1</p>
<p>Product description Installed condition and examples of use for rebars</p>	

Installation tension anchor ZA

Figure A6: Overlapping joint of a column stressed in bending to a foundation

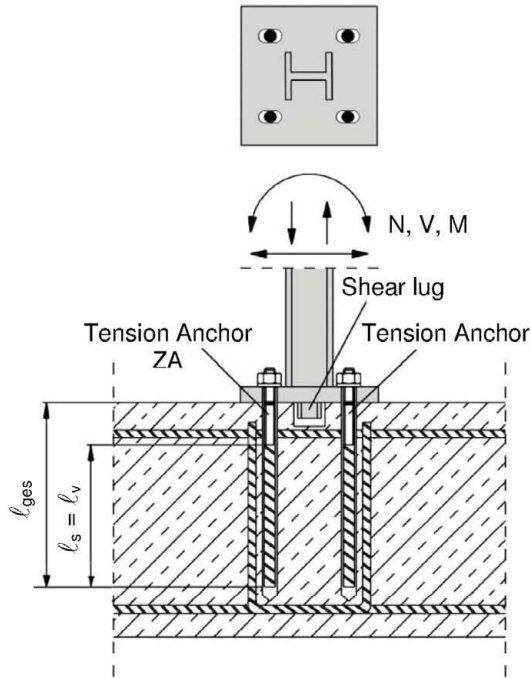

Figure A7: Overlap joint for the anchorage of barrier posts

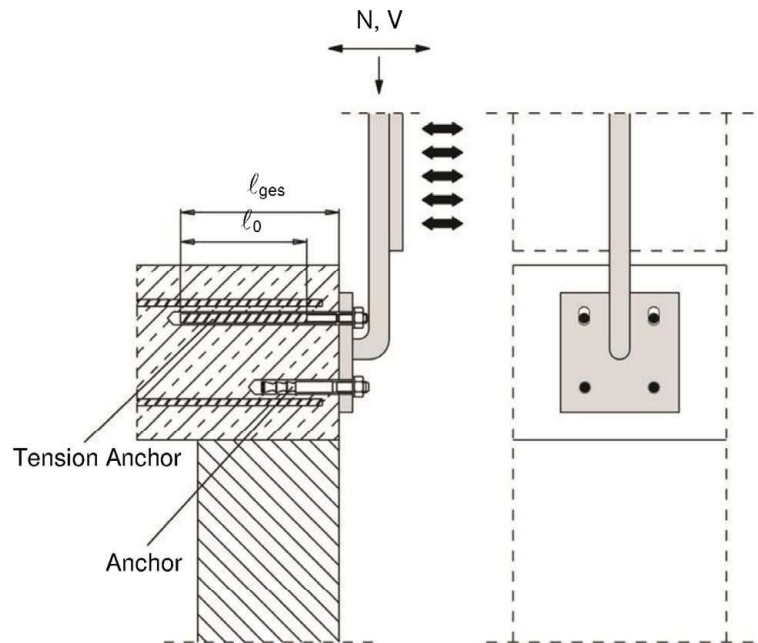
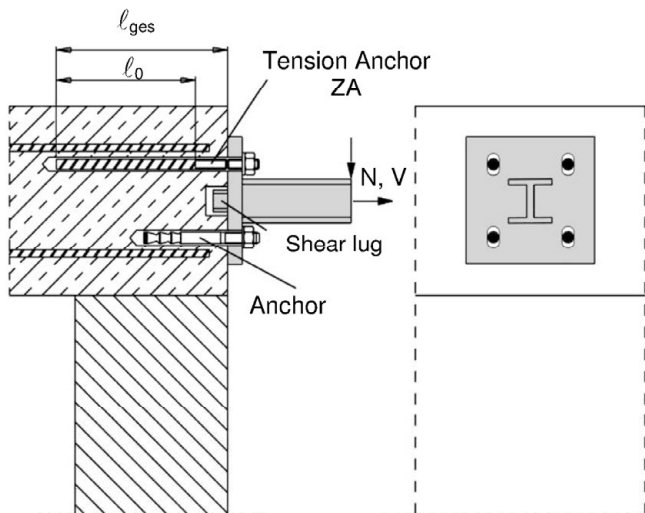

Figure A8: Overlap joint for the anchorage to cantilever members



Note to Figure A6 to A8:

In the Figures no transverse reinforcement is plotted, the transverse reinforcement shall comply with BS EN 1992-1-1: 2004 + A1: 2014

<p>VJ Technology Injection System XPE440 for rebar connection</p>	<p>Annex A 2</p>
<p>Product description Installed condition and examples of use for tension anchors ZA</p>	

VJ Technology Injection System XPE440:

Injection mortar: XPE440

Type “side-by-side”:
440ml, 585 ml and 1400 ml
cartridge

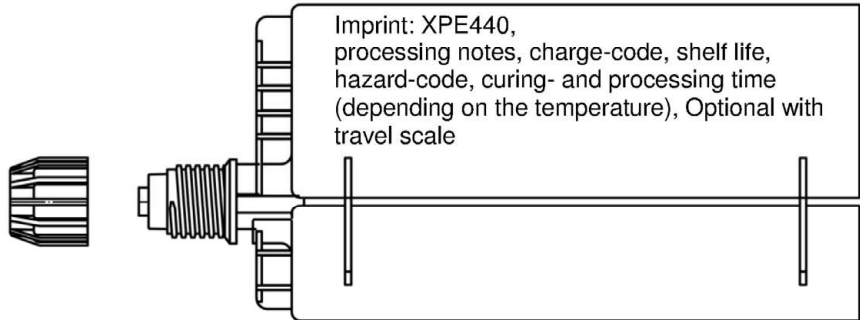

Static Mixer

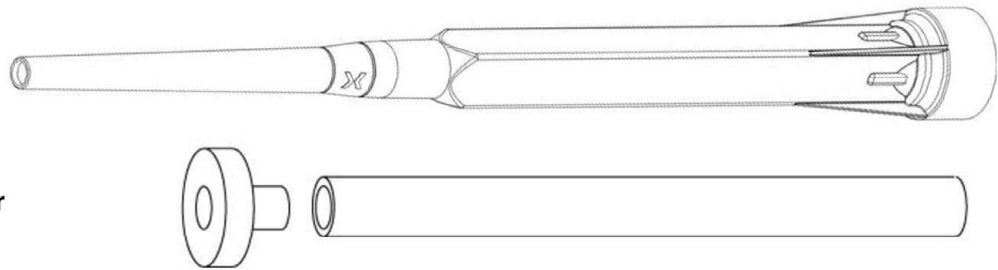

Piston plug and mixer extension

Reinforcing bar (rebar): $\varnothing 8$, $\varnothing 10$, $\varnothing 12$, $\varnothing 14$, $\varnothing 16$, $\varnothing 20$, $\varnothing 22$, $\varnothing 24$, $\varnothing 25$, $\varnothing 28$, $\varnothing 32$, $\varnothing 34$, $\varnothing 36$, $\varnothing 40$

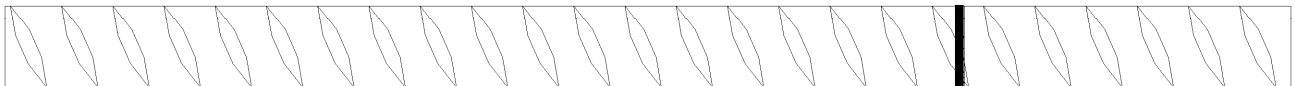

Tension Anchor ZA: M12 to M24

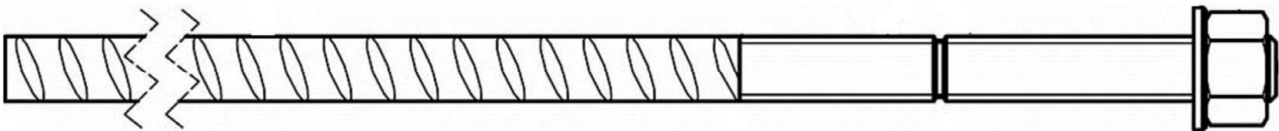

VJ Technology Injection System XPE440 for rebar connection

Product description
Injection mortar / Static mixer / Rebar / Tension Anchor ZA

Annex A 3

Reinforcing bar (rebar): $\phi 8, \phi 10, \phi 12, \phi 14, \phi 16, \phi 20, \phi 22, \phi 24, \phi 25, \phi 28, \phi 32, \phi 34, \phi 36, \phi 40$

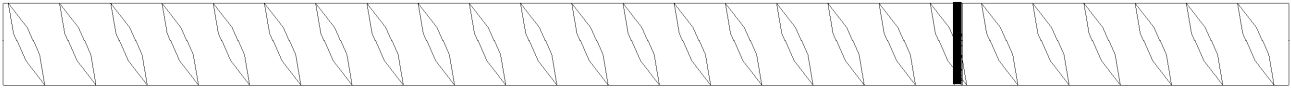



- Minimum value of related rip area $f_{R,min}$ according to BS EN 1992-1-1: 2004 + A1: 2014
- Rib height of the bar shall be in the range $0,05\phi \leq h_{rib} \leq 0,07\phi$
(ϕ : Nominal diameter of the bar; h_{rib} : Rib height of the bar)

Table A1: Materials

Designation	Material
Rebar BS EN 1992-1-1: 2004 + A1: 2014, Annex C	Bars and de-coiled rods class B or C f_{yk} and k according to NDP or NCL of BS EN 1992-1-1: 2004 + A1: 2014; $f_{uk} = f_{tk} = k \cdot f_{yk}$
VJ Technology Injection System XPE440 for rebar connection	Annex A 4
Product description Materials Rebar	

Tension Anchor ZA: M12, M16, M20, M24

Marking: e.g.  12 A4

-  Mark of the producer
- ZA Trade name
- 12 Rod diameter/thread
- A4 for stainless steel A4
- HCR for high corrosion resistance steel

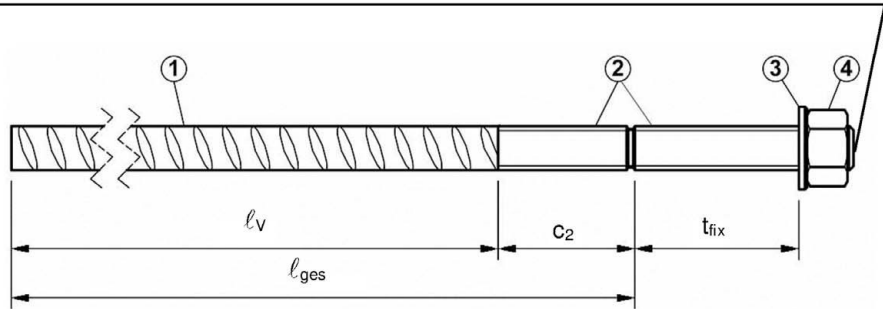

Table A2: Materials

Part	Designation	Material											
		ZA vz				ZA A4				ZA HCR			
		M12	M16	M20	M24	M12	M16	M20	M24	M12	M16	M20	M24
1	Reinforcement bar	Class B according to NDP or NCL of BS EN 1992-1-1: 2004 + A1: 2014 $f_{yk} = f_{tk} = k \cdot f_{yk}$											
2	Threaded rod	Steel, zinc plated according to BS EN ISO 683-4: 2018 or BS EN 10263: 2017				Stainless steel, 1.4362, 1.4401, 1.4404, 1.4571, BS EN 10088-1: 2014				High corrosion resistant steel, 1.4529, 1.4565, BS EN 10088-1: 2014			
		640				640		560		640		560	
3	Washer	Steel, zinc plated according to BS EN ISO 683-4: 2018 or BS EN 10263: 2017				Stainless steel, 1.4362, 1.4401, 1.4404, 1.4571, BS EN 10088-1: 2014				High corrosion resistant steel, 1.4529, 1.4565, BS EN 10088-1: 2014			
4	Nut												

Table A3: Dimensions and installation parameter

Size			ZA-M12	ZA-M16	ZA-M20	ZA-M24	
Diameter of threaded rod	d_s	[mm]	12	16	20	24	
Diameter of reinforcement bar	ϕ	[mm]	12	16	20	25	
Drill hole diameter	d_o	[mm]	16	20	25	32	
Diameter of clearance hole in fixture	d_f	[mm]	14	18	22	26	
With across nut flats	SW	[mm]	19	24	30	36	
Stress area	A_s	[mm ²]	84	157	245	353	
Effective embedment depth	l_v	[mm]	according to static calculation				
Length of bonded thread	plated	c_2	[mm]	≥ 20	≥ 20	≥ 20	≥ 20
	A4/HCR			≥ 100	≥ 100	≥ 100	≥ 100
Minimum thickness of fixture	t_{fix}	[mm]	5	5	5	5	
Maximum thickness of fixture	t_{fix}	[mm]	3000	3000	3000	3000	
Maximum installation torque	T_{max}	[Nm]	50	100	150	150	

VJ Technology Injection System XPE440 for rebar connection

Product description
Specifications Tension Anchor ZA

Annex A 5

Specifications of intended use

Anchorage subject to:

- Static and quasi-static loads.
- Fire exposure

Base materials:

- Reinforced or unreinforced normal weight concrete according to BS EN 206: 2013 + A2: 2021
- Strength classes C12/15 to C50/60 according to BS EN 206: 2013 + A2: 2021
- Maximum chloride content of 0,40% (CL 0.40) related to the cement content according to BS EN 206: 2013 + A2: 2021
- Non-carbonated concrete.

Note: In case of a carbonated surface of the existing concrete structure the carbonated layer shall be removed in the area of the post-installed rebar connection with a diameter of $\phi + 60$ mm prior to the installation of the new rebar.

The depth of concrete to be removed shall correspond to at least the minimum concrete cover in accordance with BS EN 1992-1-1: 2004 + A1: 2014

The foregoing may be neglected if building components are new and not carbonated and if building components are in dry conditions.

Temperature Range:

- - 40°C to +80°C (max. short term temperature +80°C and max long term temperature +50°C).

Use conditions (Environmental conditions) with tension anchor ZA:

- Structures subject to dry internal conditions or subject to external atmospheric exposure (including industrial and marine environment) and to permanently damp internal condition, if no particular aggressive conditions exist (stainless steel or high corrosion resistant steel).
- Structures subject to external atmospheric exposure and to permanently damp internal condition, if other particular aggressive conditions exist (high corrosion resistant steel).

Note: Particular aggressive conditions are e.g. permanent, alternating immersion in seawater or the splash zone of seawater, chloride atmosphere of indoor swimming pools or atmosphere with extreme chemical pollution (e.g. in desulphurization plants or road tunnels where de-icing materials are used).

Design:

- Anchorages are designed under the responsibility of an engineer experienced in anchorages and concrete work.
- Verifiable calculation notes and drawings are prepared taking account of the forces to be transmitted.
- Design according to BS EN 1992-1-1: 2004 + A1: 2014, BS EN 1992-1-2: 2004 + A1: 2019 and Annex B2 and B3
- The actual position of the reinforcement in the existing structure shall be determined on the basis of the construction documentation and taken into account when designing.

Installation:

- Dry or wet concrete.
- It must not be installed in flooded holes.
- Hole drilling by hammer drill (HD), hollow drill (HDB), diamond drill (DD) or compressed air drill (CD).
- The installation of post-installed rebar resp. tension anchors shall be done only by suitable trained installer and under supervision on site; the conditions under which an installer may be considered as suitable trained and the conditions for supervision on site are up to the Member States in which the installation is done.
- Check the position of the existing rebars (if the position of existing rebars is not known, it shall be determined using a rebar detector suitable for this purpose as well as on the basis of the construction documentation and then marked on the building component for the overlap joint).

VJ Technology Injection System XPE440 for rebar connection

**Intended use
Specifications**

Annex B 1

Figure B1: General construction rules for post-installed rebars

- Only tension forces in the axis of the rebar may be transmitted
- The transfer of shear forces between new concrete and existing structure shall be designed additionally according to BS EN 1992-1-1: 2004 + A1: 2014
- The joints for concreting must be roughened to at least such an extent that aggregate protrude.

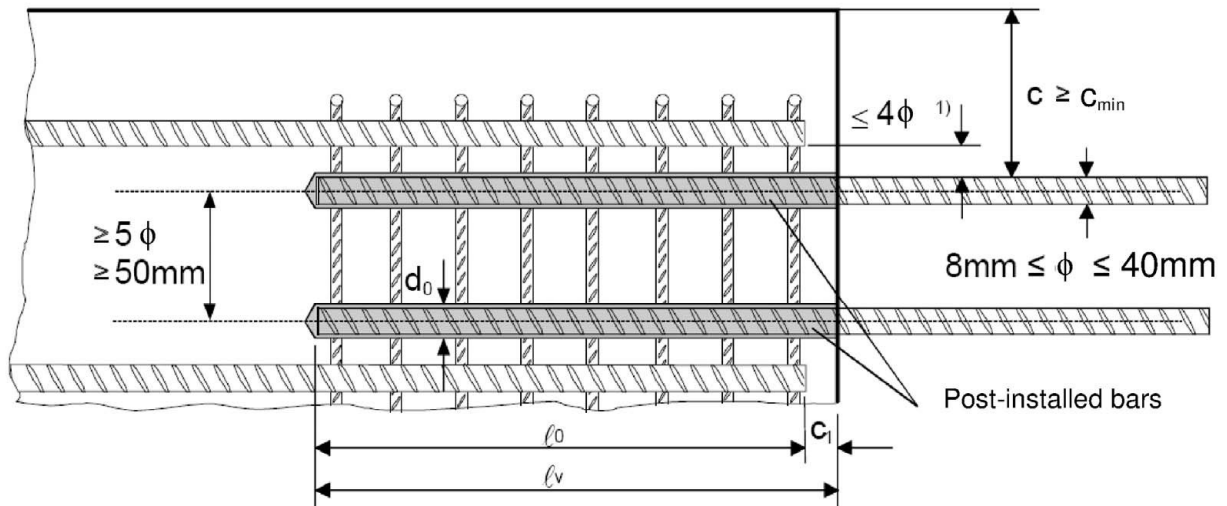

- 1) If the clear distance between lapped bars exceeds 4ϕ , then the lap length shall be increased by the difference between the clear bar distance and 4ϕ .

The following applies to Figure B1:

c	concrete cover of post-installed rebar
c_1	concrete cover at end-face of existing rebar
c_{min}	minimum concrete cover according to Table B1 and to BS EN 1992-1-1: 2004 + A1: 2014, section 4.4.1.2
ϕ	diameter of post-installed rebar
l_0	lap length, according to BS EN 1992-1-1: 2004 + A1: 2014, section 8.7.3
l_v	effective embedment depth, $\geq l_0 + c_1$
d_0	nominal drill bit diameter, see Annex B 4

VJ Technology Injection System XPE440 for rebar connection

Intended use
General construction rules for post-installed rebars

Annex B 2

Figure B2: General construction rules for tension anchors ZA

- The length of the bonded-in thread may be not be accounted as anchorage
- Only tension forces in the direction of the bar axis may be transmitted by the tension anchor ZA
- The tension force must be transferred via an overlap joint to the reinforcement in the building part.
- The transfer of shear forces shall be ensured by appropriate additional measures, e.g shear lugs or by anchors with an European technical assessment.
- In the anchor plate, the holes for the tension anchors shall be executed as elongated holes with axis in the direction of the shear force.

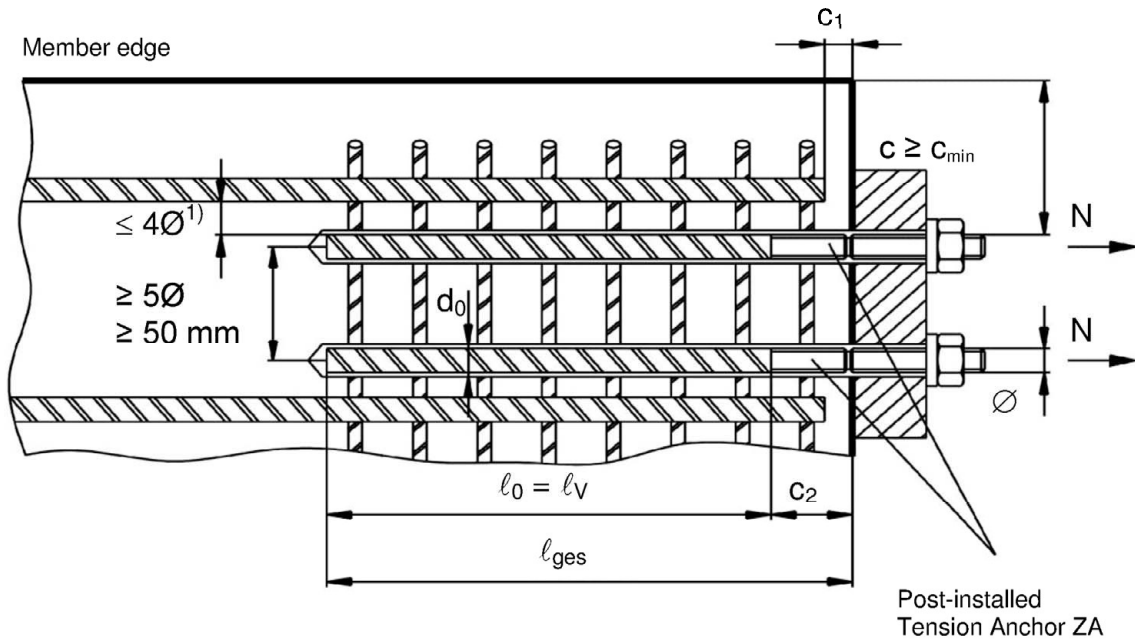

¹⁾ If the clear distance between lapped bars exceeds 4ϕ , then the lap length shall be increased by the difference between the clear bar distance and 4ϕ .

The following applies to Figure B2:

c	concrete cover of tension anchor ZA
c_1	concrete cover at end-face of existing rebar
c_2	Length of bonded thread
c_{min}	minimum concrete cover according to Table B1 and to BS EN 1992-1-1: 2004 + A1: 2014, section 4.4.1.2
ϕ	diameter of tension anchor
l_0	lap length, according to BS EN 1992-1-1: 2004 + A1: 2014, section 8.7.3
l_v	effective embedment depth, $\geq l_0 + c_1$
l_{ges}	overall embedment depth, $\geq l_0 + c_2$
d_0	nominal drill bit diameter, see Annex B 4

VJ Technology Injection System XPE440 for rebar connection

Intended use
General construction rules for tension anchors

Annex B 3

Table B1: Minimum concrete cover min $c^{1)}$ of post-installed rebar and tension anchor ZA depending of drilling method

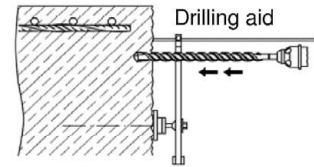

Drilling method	Rebar diameter	Without drilling aid	With drilling aid
Hammer drilling (HD) Hollow drilling (HDB)	< 25 mm	$30 \text{ mm} + 0,06 \cdot l_v \geq 2 \phi$	$30 \text{ mm} + 0,02 \cdot l_v \geq 2 \phi$
	$\geq 25 \text{ mm}$	$40 \text{ mm} + 0,06 \cdot l_v \geq 2 \phi$	$40 \text{ mm} + 0,02 \cdot l_v \geq 2 \phi$
Diamond drilling (DD)	< 25 mm	Drill rig used as drilling aid	$30 \text{ mm} + 0,02 \cdot l_v \geq 2 \phi$
	$\geq 25 \text{ mm}$		$40 \text{ mm} + 0,02 \cdot l_v \geq 2 \phi$
Compressed air drilling (CD)	< 25 mm	$50 \text{ mm} + 0,08 \cdot l_v$	$50 \text{ mm} + 0,02 \cdot l_v$
	$\geq 25 \text{ mm}$	$60 \text{ mm} + 0,08 \cdot l_v$	$60 \text{ mm} + 0,02 \cdot l_v$

¹⁾ see Annex B 2, Figure B1 and Annex B 3, Figure B2
Comments: The minimum concrete cover acc. BS EN 1992-1-1: 2004 + A1: 2014

Table B2: maximum embedment depth $l_{v,max}$

Rebar ϕ	Tension anchor ϕ	HD / CD / DD $l_{v,max}$ [mm]	HDB $l_{v,max}$ [mm]
8 mm		800	800
10 mm		1000	1000
12 mm	ZA-M12	1200	1000
14 mm		1400	1000
16 mm	ZA-M16	1600	1000
20 mm	ZA-M20	2000	1000
22 mm		2000	1000
24 mm		2000	1000
25 mm	ZA-M24	2000	1000
28 mm		2000	1000
32 mm		2000	1000
34 mm		2000	-
36 mm		2000	-
40 mm		2000	-





Table B3: Base material temperature, gelling time and curing time

Concrete temperature	Gelling- / working time ¹⁾ t_{gel}	Minimum curing time in dry concrete $t_{cure,dry}$	Minimum curing time in wet concrete $t_{cure,wet}$
+ 5 °C to + 9°C	80 min	48 h	96 h
+ 10 °C to + 14°C	60 min	28 h	56 h
+ 15 °C to + 19°C	40 min	18 h	36 h
+ 20 °C to + 24°C	30 min	12 h	24 h
+ 25 °C to + 34°C	12 min	9 h	18 h
+ 35 °C to + 39°C	8 min	6 h	12 h
+40 °C	8 min	4 h	8 h
Cartridge temperature	+5°C to +40°C		

¹⁾ t_{gel} : maximum time from starting of mortar injection to completing of rebar setting.

VJ Technology Injection System XPE440 for rebar connection	Annex B 4
Intended use Minimum concrete cover Maximum embedment depth	

Table B4: Dispensing tools

Cartridge type/size	Hand tool		Pneumatic tool
Side-by-side cartridges 440, 585 ml	 e.g. SA 296C585	 e.g. Typ H 244 C	 e.g. Typ TS 444 KX
Side-by-side cartridges 1400 ml	-	-	 e.g. Typ TS 471

Cleaning and installation tools

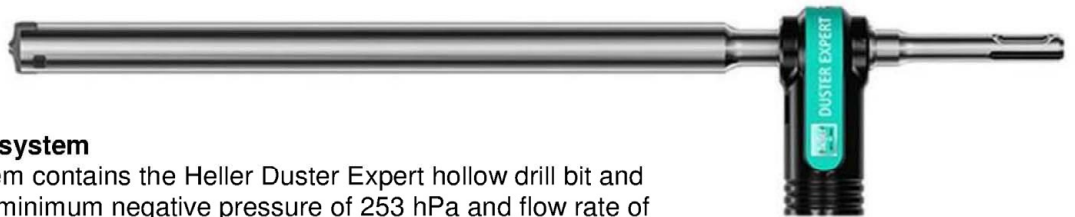

HDB – Hollow drill bit system

The hollow drill bit system contains the Heller Duster Expert hollow drill bit and a class M vacuum with minimum negative pressure of 253 hPa and flow rate of minimum 150 m³/h (42 l/s).

Brush BR:

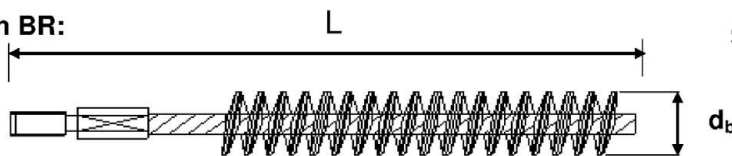

SDS Plus Adapter:



Brush extension:



Rec. compressed air tool
hand slide valve (min 6 bar)



VJ Technology Injection System XPE440 for rebar connection

Intended Use
Dispensing, cleaning and installation tools

Annex B 5

Table B5: Brushes, piston plugs, max anchorage depth and mixer extension, hammer (HD), diamond (DD) and compressed air (CD) drilling

Bar size ϕ [mm]	Tension anchor ϕ [mm]	Drill bit - ϕ			d_b Brush - ϕ [mm]	$d_{b,min}$ min. Brush - ϕ [mm]	Piston plug	Cartridge: 440 ml or 585 ml				Cartridge: 1400 ml			
		HD	DD	CD				Hand or battery tool		Pneumatic tool		Pneumatic tool			
								$l_{v,max}$ [mm]	Mixer extension	$l_{v,max}$ [mm]	Mixer extension	$l_{v,max}$ [mm]	Mixer extension		
8	-	10	-	BR10	11,5	10,5	-	250	VL10/0,75 or VL16/1,8	250	VL10/0,75 or VL16/1,8	250	VL10/0,75 or VL16/1,8		
	-	12	-	BR12	13,5	12,5	-	700		800		800			
10	-	14	-	BR14	15,5	14,5	PP14	250		250		250			
	-							700		1000		1000			
12	ZA-M12	16		BR16	17,5	16,5	PP16	250		1300		250		1200	VL16/1,8
14	-							18				BR18		20,0	
16	ZA-M16	20		BR20	22,0	20,5	PP20	500		VL10/0,75 or VL16/1,8		1600		VL16/1,8	
20	ZA-M20	25	-	BR25	27,0	25,5	PP25					1000			2000
	-	26	BR26	28,0	26,5	PP25									
22	-	28		BR28	30,0	28,5	PP28								
24/25	ZA-M24	32		BR32	34,0	32,5	PP32								
28	-	35		BR35	37,0	35,5	PP35								
32/34	-	40		BR40	43,5	40,5	PP40								
36	-	45		BR45	47,0	45,5	PP45								
40	-	52	-	BR52	54,0	52,5	PP52		-		-				
	-	55	-	BR55	58,0	55,5	PP55		-		-				

Table B6: Brushes, piston plugs, max anchorage depth and mixer extension, hammer drilling with hollow drill bit system (HDB)

Bar size ϕ [mm]	Tension anchor ϕ [mm]	Drill bit - ϕ	d_b Brush - ϕ [mm]	$d_{b,min}$ min. Brush - ϕ [mm]	Piston plug	Cartridge: 440 ml or 585 ml				Cartridge: 1400 ml						
		HDB				Hand or battery tool		Pneumatic tool		Pneumatic tool						
		$l_{v,max}$ [mm]				Mixer extension	$l_{v,max}$ [mm]	Mixer extension	$l_{v,max}$ [mm]	Mixer extension						
8	-	10	No cleaning required		-	250	VL10/0,75 or VL16/1,8	1000	VL10/0,75 or VL16/1,8	250	VL10/0,75 or VL16/1,8					
	-	12			-	700				800		800				
10	-	14			PP14	250				250		250				
	-					700				1000		1000				
12	ZA-M12	16			PP16	250				700		VL10/0,75 or VL16/1,8	1000	VL10/0,75 or VL16/1,8	250	1000
14	-					18									PP18	
16	ZA-M16	20			PP20											
20	ZA-M20	25			PP25											
22	-	28			PP28											
24/25	ZA-M24	32			PP32	500										
28	-	35			PP35											
32/34	-	40			PP40											

VJ Technology Injection System XPE440 for rebar connection

Intended use
Installation tools

Annex B 6

A) Bore hole drilling

Note: Before drilling, remove carbonated concrete and clean contact areas (see Annex B1)
 In case of aborted drill hole: the drill hole shall be filled with mortar.

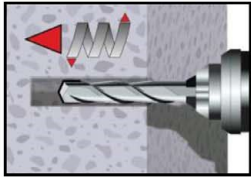

- 1a. Hammer (HD) or compressed air drilling (CD)**
 Drill a hole into the base material to the size and embedment depth required by the selected reinforcing bar
 Proceed with Step B1.



Hammer drill (HD + HDB)

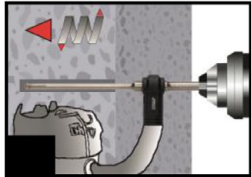

- 1b. Hollow drill bit system (HDB)** (see Annex B 5)
 Drill a hole into the base material to the size and embedment depth required by the selected reinforcing bar.
 This drilling system removes the dust and cleans the bore hole during drilling. Proceed with Step C.

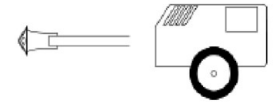

Compressed air drill (CD)

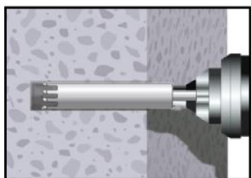

- 1c. Diamond drilling (DD)**
 Drill with diamond drill a hole into the base material to the size and embedment depth required by the selected anchor
 Proceed with Step B2.



Diamond coring (DD)

B1) Bore hole cleaning

CAC: Cleaning for all bore hole diameter and bore hole depth with drilling method HD and CD

Attention! Standing water in the bore hole must be removed before cleaning.

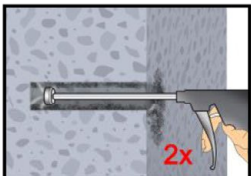

- 2a.** Starting from the bottom or back of the bore hole, blow the hole clean with compressed air (min. 6 bar) (Annex B 7) a minimum of two times until return air stream is free of noticeable dust. If the bore hole ground is not reached an extension shall be used

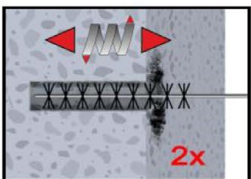

- 2b.** Check brush diameter (Table B5). Brush the hole with an appropriate sized wire brush $> d_{b,min}$ (Table B5) a minimum of two times.
 If the bore hole ground is not reached with the brush, a brush extension shall be used (Table B5).

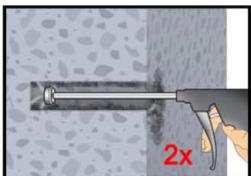

- 2c.** Finally blow the hole clean again with compressed air (min. 6 bar) (Annex B 7) a minimum of two times until return air stream is free of noticeable dust. If the bore hole ground is not reached an extension shall be used.

After cleaning, the bore hole has to be protected against re-contamination in an appropriate way, until dispensing the mortar in the bore hole. If necessary, the cleaning has to be repeated directly before dispensing the mortar. In-flowing water must not contaminate the bore hole again.

VJ Technology Injection System XPE440 for rebar connection

Intended use

Installation instruction: Bore hole drilling and cleaning (HD, HDB and CD)

Annex B 7

B2) Bore hole cleaning

SPCAC: Cleaning for all bore hole diameter and bore hole depth with drilling method DD

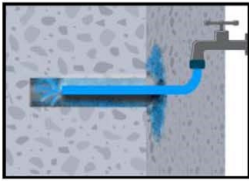

2a. Rinsing with water until clear water comes out.

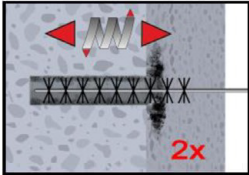

2b. Check brush diameter (Table B5). Brush the hole with an appropriate sized wire brush $> d_{b,min}$ (Table B5) a minimum of two times in a twisting motion. If the bore hole ground is not reached with the brush, a brush extension must be used.

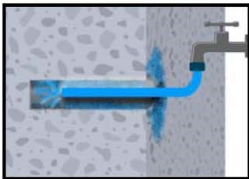

2c. Rinsing again with water until clear water comes out.

Attention! Standing water in the bore hole must be removed before proceed cleaning.

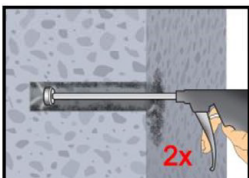

2d. Starting from the bottom or back of the bore hole, blow the hole clean with compressed air (min. 6 bar) (Annex B 7) a minimum of two times until return air stream is free of noticeable dust. If the bore hole ground is not reached an extension shall be used

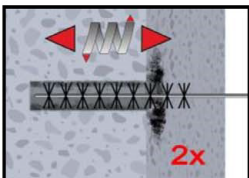

2e. Check brush diameter (Table B5). Brush the hole with an appropriate sized wire brush $> d_{b,min}$ (Table B5) a minimum of two times. If the bore hole ground is not reached with the brush, a brush extension shall be used (Table B5).

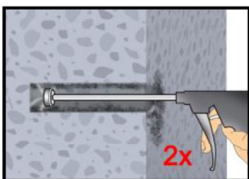

2f. Finally blow the hole clean again with compressed air (min. 6 bar) (Annex B 7) a minimum of two times until return air stream is free of noticeable dust. If the bore hole ground is not reached an extension shall be used.

After cleaning, the bore hole has to be protected against re-contamination in an appropriate way, until dispensing the mortar in the bore hole. If necessary, the cleaning has to be repeated directly before dispensing the mortar. In-flowing water must not contaminate the bore hole again.

VJ Technology Injection System XPE440 for rebar connection

Intended use
Installation instruction: Bore hole drilling and cleaning (DD)

Annex B 8

C) Preparation of bar and cartridge

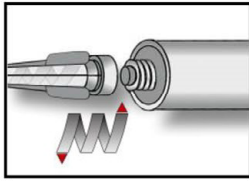

- 3a. Attach the supplied static-mixing nozzle to the cartridge and load the cartridge into the correct dispensing tool.
For every working interruption longer than the recommended working time (Table B3) as well as for every new cartridges, a new static-mixer shall be used.

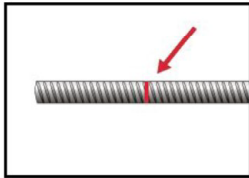

- 3b. Prior to inserting the reinforcing bar into the filled bore hole, the position of the embedment depth shall be marked (e.g. with tape) on the reinforcing bar and insert bar in empty hole to verify hole and depth l_v .
The anchor should be free of dirt, grease, oil or other foreign material.

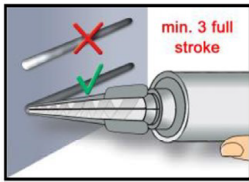

- 3c. Prior to dispensing into the bore hole, squeeze out separately the mortar until it shows a consistent grey or red colour, but a minimum of three full strokes, and discard non-uniformly mixed adhesive components.

D) Filling the bore hole

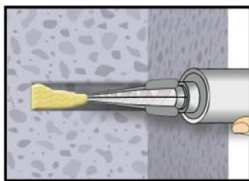

4. Starting from the bottom or back of the cleaned bore hole fill the hole with adhesive, until the level mark at the mixer extension (see below) is visible at the top of the hole. For embedment larger than 190 mm an extension nozzle shall be used. Slowly withdraw the static mixing nozzle and using a piston plugs during injection of the mortar, helps to avoid creating air pockets.

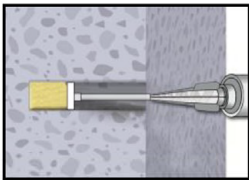

For overhead and horizontal installation and bore holes deeper than 240 mm a piston plug and the appropriate mixer extension must be used.

Observe the gel-/ working times given in Table B3.

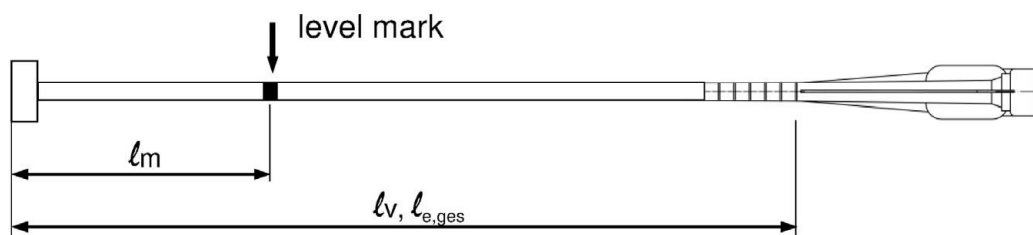

Injection tool must be marked by mortar level mark l_m and anchorage depth l_v resp. $l_{e,ges}$ with tape or marker.

Quick estimation: $l_m = 1/3 \cdot l_v$

Continue injection until the mortar level mark l_m becomes visible.

Optimum mortar volume: $l_m = l_v \text{ resp } l_{e,ges} \cdot \left(1,2 \cdot \frac{\phi^2}{d_0^2} - 0,2 \right)$ [mm]

VJ Technology Injection System XPE440 for rebar connection

Intended Use

Installation instruction: Preparation of bar and cartridge
Filling the bore hole

Annex B 9

E) Setting the rebar

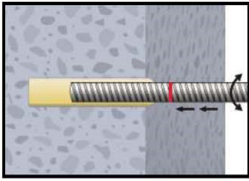

5a. Push the reinforcing bar into the bore hole while turning slightly to ensure positive distribution of the adhesive until the embedment depth is reached.

The bar should be free of dirt, grease, oil or other foreign material.

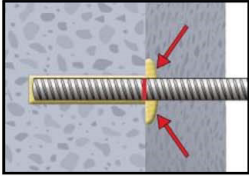

5b. Be sure that the bar is inserted in the bore hole until the embedment mark is at the concrete surface and that excess mortar is visible at the top of the hole. If these requirements are not maintained, the application has to be renewed. For horizontal and overhead installation fix embedded part (e.g. with wedges).

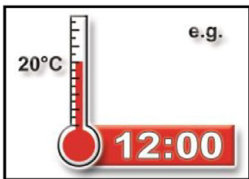

5c. Observe gelling time t_{gel} . Attend that the gelling time can vary according to the base material temperature (see Table B3). Do not move or load the bar until full curing time t_{cure} has elapsed (attend Table B3).

VJ Technology Injection System XPE440 for rebar connection

Intended Use

Installation instruction: Inserting rebar

Annex B 10

Minimum anchorage length and minimum lap length

The minimum anchorage length $\ell_{b,min}$ and the minimum lap length $\ell_{0,min}$ according to BS EN 1992-1-1: 2004 + A1: 2014 ($\ell_{b,min}$ acc. to Eq. 8.6 and Eq. 8.7 and $\ell_{0,min}$ acc. to Eq. 8.11) shall be multiply by the amplification factor α_{lb} according to Table C1

Table C1: Amplification factor α_{lb} related to concrete class and drilling method

Concrete class	Drilling method	Bar size	Amplification factor α_{lb}
C12/15 to C50/60	all drilling methods	8 mm to 40 mm ZA-M12 to ZA-M24	1,0

Table C2: Reduction factor k_b for all drilling methods

Rebar ϕ	Concrete class								
	C12/15	C16/20	C20/25	C25/30	C30/37	C35/45	C40/50	C45/55	C50/60
8 to 40 mm ZA-M12 to ZA-M24	1,0								

Table C3: Design values of the ultimate bond stress $f_{bd,PIR}$ in N/mm² for all drilling methods and for good conditions

$$f_{bd,PIR} = k_b \cdot f_{bd}$$

with

f_{bd} : Design value of the ultimate bond stress in N/mm² considering the concrete classes, the rebar diameter, the drilling method according to BS EN 1992-1-1: 2004 + A1: 2014 (for all other bond conditions multiply the values by 0.7)

k_b : Reduction factor according to Table C2

Rebar ϕ	Concrete class								
	C12/15	C16/20	C20/25	C25/30	C30/37	C35/45	C40/50	C45/55	C50/60
8 to 32 mm ZA-M12 to ZA-M24	1,6	2,0	2,3	2,7	3,0	3,4	3,7	4,0	4,3
34 mm	1,6	2,0	2,3	2,6	2,9	3,3	3,6	3,9	4,2
36 mm	1,5	1,9	2,2	2,6	2,9	3,3	3,6	3,8	4,1
40 mm	1,5	1,8	2,1	2,5	2,8	3,1	3,4	3,7	4,0

VJ Technology Injection System XPE440 for rebar connection

Performances

Amplification factor α_{lb} , Reduction factor k_b
Design values of ultimate bond resistance $f_{bd,PIR}$

Annex C 1

Design value of the ultimate bond stress $f_{bd,fi}$ under fire exposure for concrete classes C12/15 to C50/60, (all drilling methods):

The design value of the bond strength $f_{bd,fi}$ under fire exposure has to be calculated by the following equation:

$$f_{bd,fi} = k_{fi}(\theta) \cdot f_{bd,PIR} \cdot \gamma_c / \gamma_{M,fi}$$

with: $\theta \leq 278^\circ\text{C}$: $k_{fi}(\theta) = 4673,8 \cdot \theta^{-1,598} / (f_{bd,PIR} \cdot 4,3) \leq 1,0$
 $\theta > 278^\circ\text{C}$: $k_{fi}(\theta) = 0$

$f_{bd,fi}$ Design value of the ultimate bond stress in case of fire in N/mm²

θ Temperature in °C in the mortar layer.

$k_{fi}(\theta)$ Reduction factor under fire exposure.

$f_{bd,PIR}$ Design value of the ultimate bond stress in N/mm² in cold condition according to Table C3 considering the concrete classes, the rebar diameter, the drilling method and the bond conditions according to BS EN 1992-1-1: 2004 + A1: 2014

γ_c partially safety factor according to BS EN 1992-1-1: 2004 + A1: 2014

$\gamma_{M,fi}$ partially safety factor according to BS EN 1992-1-2: 2004 + A1: 2019

For evidence under fire exposure the anchorage length shall be calculated according to BS EN 1992-1-1: 2004 + A1: 2014 Equation 8.3 using the temperature-dependent ultimate bond stress $f_{bd,fi}$

Example graph of Reduction factor $k_{fi}(\theta)$ for concrete classes C20/25 for good bond conditions:

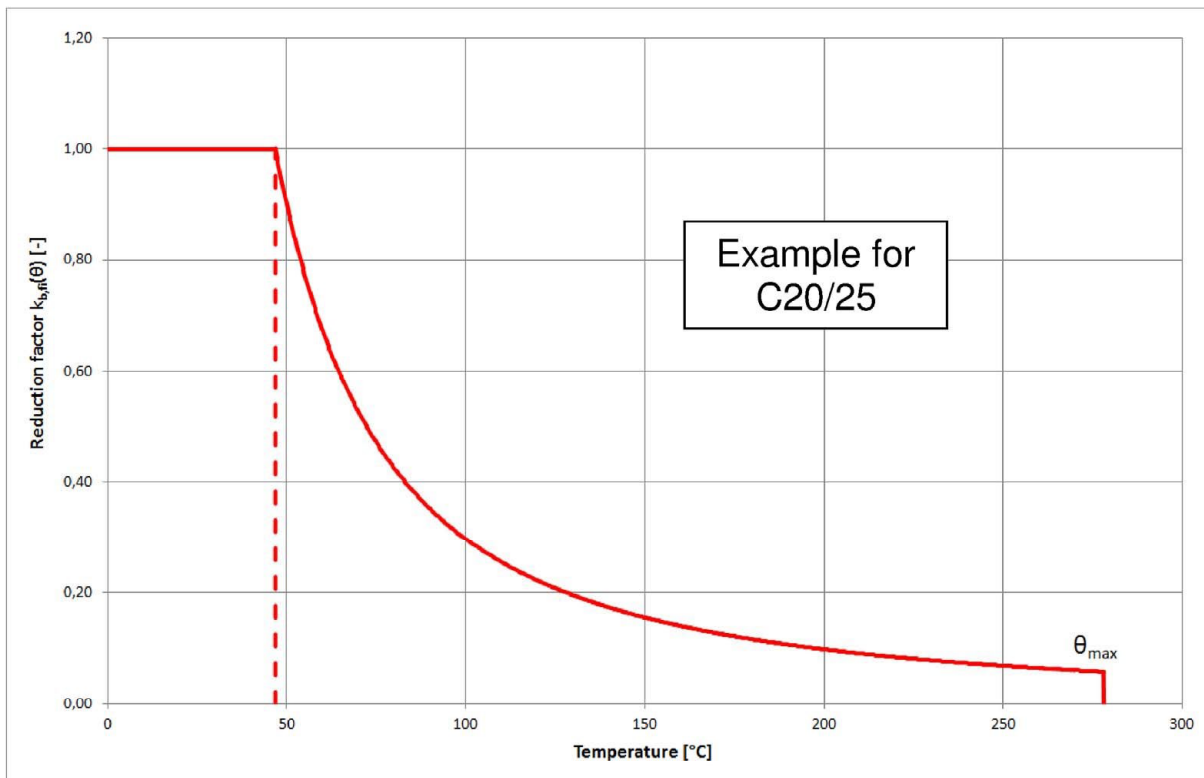

VJ Technology Injection System XPE440 for rebar connection

Performances

Design value of bond strength $f_{bd,fi}$ under fire exposure

Annex C 2

Table C6: Characteristic tension strength for tension anchor ZA under fire exposure,
concrete classes C12/15 to C50/60, according to Technical Report TR 020

Tension Anchor				M12	M16	M20	M24
Steel, zinc plated (ZA vz)							
Characteristic steel strength	R30	$\sigma_{Rk,s,fi}$	[N/mm ²]	20			
	R60			15			
	R90			13			
	R120			10			
Stainless Steel (ZA A4 or ZA HCR)							
Characteristic steel strength	R30	$\sigma_{Rk,s,fi}$	[N/mm ²]	30			
	R60			25			
	R90			20			
	R120			16			

Design value of the steel strength $\sigma_{Rd,s,fi}$ under fire exposure

The design value of the steel strength $\sigma_{Rd,s,fi}$ under fire exposure has to be calculated by the following equation:

$$\sigma_{Rd,s,fi} = \sigma_{Rk,s,fi} / \gamma_{M,fi}$$

with:

$\sigma_{Rk,s,fi}$ characteristic steel strength according to Table C4

$\gamma_{M,fi}$ partial safety factor according to BS EN 1992-1-2: 2004 + A1: 2019

VJ Technology Injection System XPE440 for rebar connection

Performances

Design value of the steel strength $\sigma_{Rd,s,fi}$ for tension anchor ZA under fire exposure

Annex C 3



British Board of Agrément,
1st Floor Building 3
Hatters Lane
Croxley Park
Watford
WD18 8YG